

HP RANGE

HIGH PERFORMANCE MOTORS
STAND ALONE MOTOR - HPS
COMBINED MOTOR & DRIVE - HPC
MOTOR WITH INTEGRATED DRIVE - HPI



HP Combi +
Plus

HP Combi

Evolving from Lafert to Lafert



Endless integrated solutions

Since inception we have overseen strategic positions and evolved together with the markets. We have led the way in the world of energy efficiency and environmental sustainability. We have always been, and still are, the market leader of product customisation.

"From Lafert to Lafert" represents the evolution that confirms the desire to progress in the wake of our company history which has always resulted in absolute quality.

Now we target an innovative but solid route to give you just what you need, with the flexibility of integrated solutions. This means better understanding the needs of a continually changing market and consequently building a clear path for the future.

For these reasons we are member of the large international industry group Sumitomo Drive Technologies.

Evolving from Lafert to Lafert

Our watchword is “evolution”, because we face new challenges every day with a clear vision for constant improvement.

Through company choices, inhouse skills and market demands, we have always been committed to technological innovation that matures over time.

Lafert Group, with 60 years of experience and our partnerships with international players, represents innovation that evolves, does not stop, and continues to adapt “**endless integrated solutions**”.

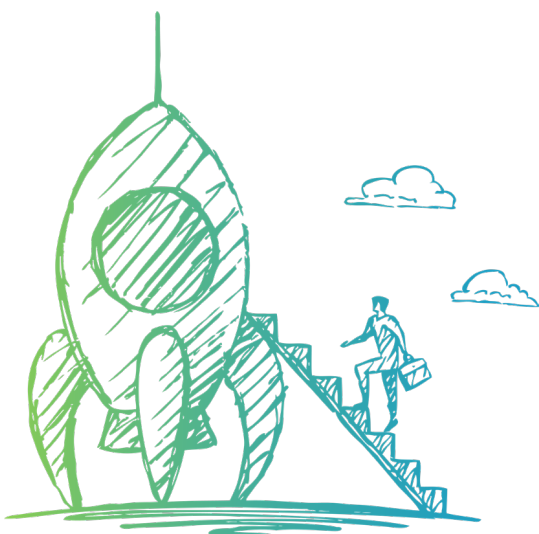

Whatever we do we think big

We are European leaders in the designing and manufacturing of customized electric motors and drives used primarily in the fields of industrial automation, energy saving and renewables.

Each individual company of our group contributes to the success of the organization through their specialized strength in design and production. The combined knowledge of the organization supports the continuous research and development of innovative technologies.

It is a great responsibility that we assume for the world and future generations, an awareness that allows us to understand the future, to think big, and to anticipate the next global needs to **achieve a more efficient and sustainable world**.

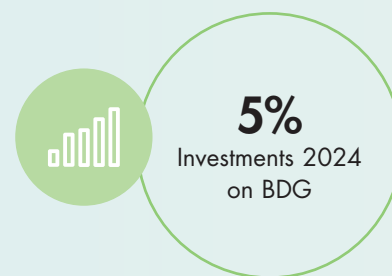

The key is technological development

Evolution requires technological development, testing ourselves with global challenges and striving to achieve new energy standards. Since our establishment, we have constantly valued research and development. Thanks to our flexible design and production capabilities, we are able to quickly respond to the global market with new ideas.

The endless future applications of our products ensure that Lafert Group will always evolve and adapt with time. This can be demonstrated by the introduction of permanent magnet technologies, the creation of highly efficient IE4 and IE5 products and the integration between electromechanical technologies.

Our focus on technological innovation is the key to achieving **greater efficiency performance in variable speeds, maximum energy savings and a compact design.**



Our global presence

We offer the highest flexibility in design and operate across **thirteen locations in Europe, North America, Asia and Australia.** Our 6 production units work closely to coordinate the integration of production processes. This allows us to offer customized technological solutions to meet market demands.

Since 2018 we have been member of the large international group **Sumitomo**. Thanks to the ambitious investment plan, organizational strengthening, and complementary internal production capabilities, many business opportunities have already developed and will continue to grow in the near future.

We have created a powerful claim, a statement that sets a long-term goal and represents the ideal to which we aim to.

Shaping the future together



Sumitomo Drive Technologies
LAFERTGROUP
 InvertekDrives.com

RANGE OF PRODUCTS (2023)

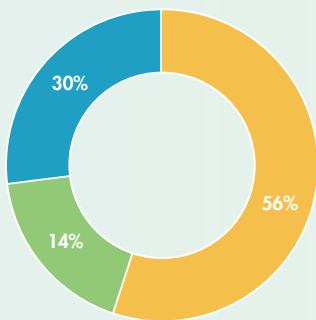

- ASYNCHRONOUS MOTORS
- SYNCHRONOUS MOTORS & DRIVES
- BRUSHLESS SERVO MOTORS & DRIVES

FIELDS OF APPLICATION (2023)

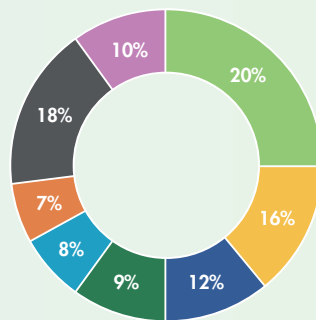

- HVAC/R
- AIR TECHNOLOGY
- INDUSTRIAL MACHINERY
- ROBOTICS
- WIND ENERGY
- MATERIAL HANDLING / AGV
- SYSTEMS INTEGRATORS
- DISTRIBUTION

BUSINESS PRESENCE (2023)

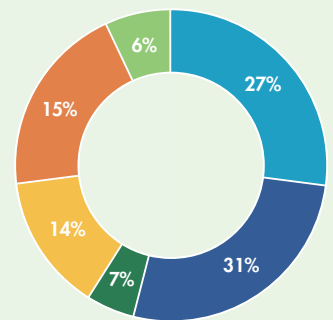

- ITALY
- GERMAN SPEAKING COUNTRIES
- SCANDINAVIAN COUNTRIES
- REST OF EUROPE
- NORTH AMERICA
- REST OF THE WORLD

GENERAL INFORMATION	3
MERGING TECHNOLOGIES	4
TECHNICAL DESCRIPTIONS	8
Brief description	
Definitions	
STANDARDS AND REGULATIONS	9
CONDITIONS OF INSTALLATION	15
Electrical/mechanical tolerances	
Thermal protection and derating	
Derating for ambient temperature, air pressure, running at low speed	
ELECTRICAL DESIGN	18
Galvanic isolation (PELV)	
Heart leakage current	
Over voltage protection	
Mains supply interference/harmonics	
MECHANICAL DESIGN	21
Degrees of protection	
Mounting arrangements	
Bearing lubrication and maintenance	
Cooling	
Vibration	
MOTOR NAMEPLATE	24
 HPS - STAND ALONE MOTOR	 25
PERFORMANCE DATA	26
Super Premium Efficiency - IE4	
Ultra Premium Efficiency - IE5	
DIMENSIONS	36
 HPC - COMBINED MOTOR & DRIVE	 41
RANGE OVERVIEW	42
VARIABLE FREQUENCY DRIVES	43
PERFORMANCE DATA	46
DIMENSIONS	51
 HPI - MOTOR WITH INTEGRATED DRIVE	 53
RANGE OVERVIEW	54
VARIABLE FREQUENCY DRIVES	55
PERFORMANCE DATA	58
DIMENSIONS	60

GENERAL INFORMATION

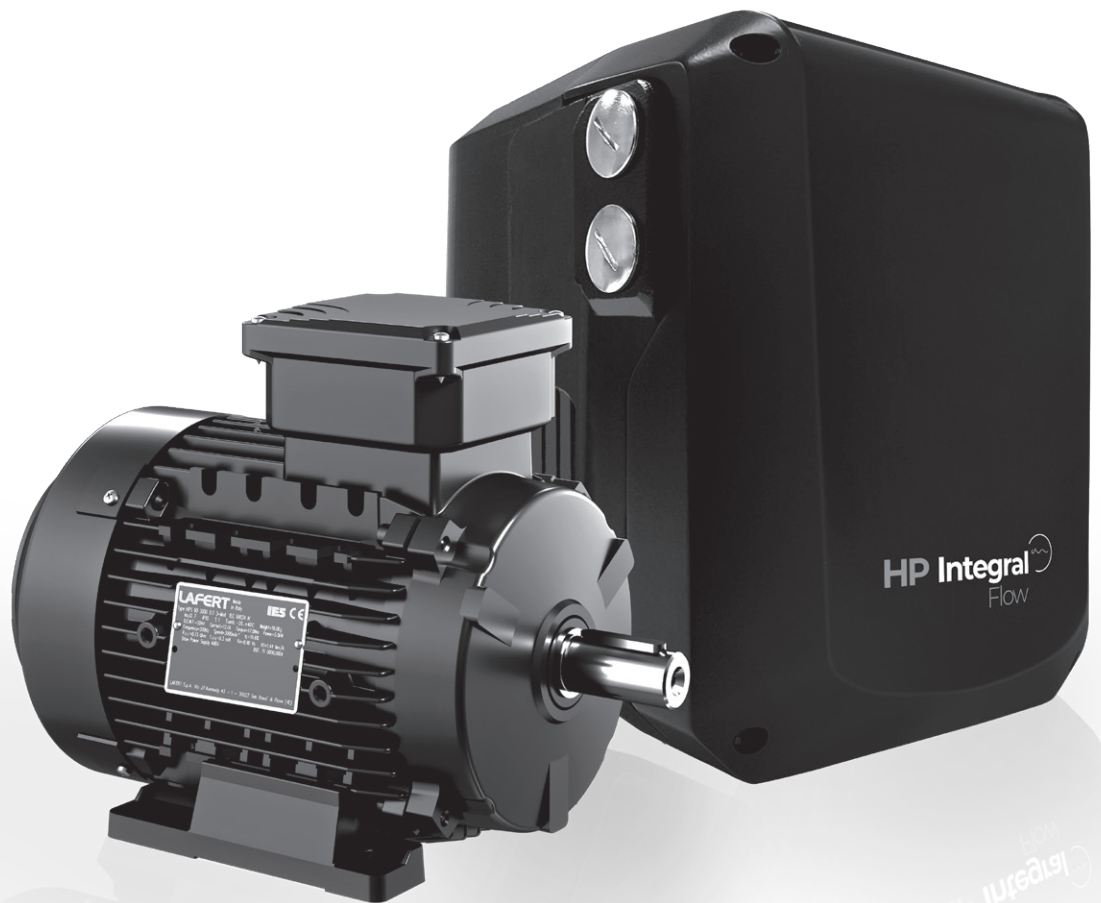

LEVERAGING LEADING-EDGE TECHNOLOGIES

High Performance Motors (HPS range) are an innovative range of PM (**Permanent Magnet**) **Synchronous Motors**, achieving **IE4 Super Premium Efficiency** and **IE5 Ultra Premium Efficiency** and offering improved performance and reduced operating costs.

Lafert's in-house servo and AC induction motor design have facilitated the development of this uniquely engineered range of motors. In order to develop the HP Motor, Lafert used a combination of product designs inspired by the brushless servo motor's electrical design and the AC induction motor's mechanical design. With higher efficiencies than standard AC induction motors they also enhance the power/weight ratio, thereby allowing for significant **size and weight reductions of up to 50%**.

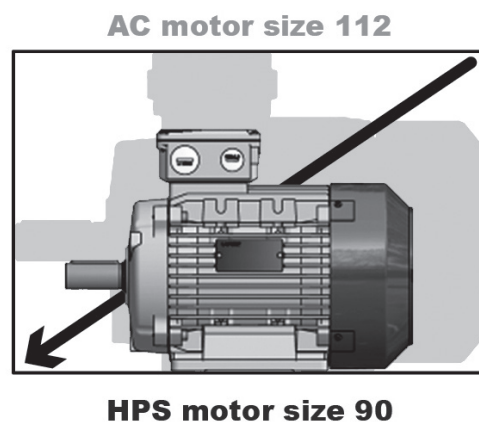

Lafert's current range of PM Motors, are based upon **Surface Mounted Permanent Magnet Motor (SMPM) design**. Permanent magnet electric motors typically use rare earth elements such as Samarium and Neodymium in the construction of the magnet elements. The commodity price of such elements has been increasing year on year over the past decade. Therefore, in order to address these market challenges, Lafert have introduced an innovative, cost effective **Interior Permanent Magnet Electric Motor (IPM)** design that will be better positioned to enjoy a key competitive edge, with more stable and reduced production costs **without applying rare earth magnets**.

The Lafert PM rotor technology grants no losses. In fact, stator currents are low, consequently generating low losses due to low current demand (Joule effect). The resulting benefit is a low rated temperature rise for both the windings and bearings. These limited temperature rises can, in the right design, eliminate the need for a cooling fan and its related losses. Finally, the sum of these minimized heat contributions provides higher running speeds and extended bearing life.

VALUE ADDED FEATURES & BENEFITS

The primary benefit offered by Lafert's HP Synchronous Motor is the reduction in the life cycle cost of the motor. The combination of servo brushless and induction motor technology used for the development of this product gives it a high efficiency and low noise design. Because of the higher efficiency, the product dissipates lower heat, which improves its operating life.

Thanks to the torque and the high efficiency, available through the complete speed range, the HPS series is targeted to both **quadratic torque applications**, typically in HVAC, as well as to **constant torque applications** like material handling, air compressors and vacuum pumps. These applications require high performances in continuous operation under variable speed, reducing the operating cost and weight/size of the system.

The complete range 0.37 kW to 37 kW are supplied as **stand-alone motors (HPS range)**, **as motor-drive combined package (HPC range)**, or **as motor-drive integrated unit (HPI range)** specifically designed for their energy saving potential.

Lafert also offer flexibility in terms of design, customising the active and mechanical parts of the motor to suit specific customer requirements.



INCREASED CUSTOMER ROI

The high operating efficiency offered by Lafert PM Motor leads to lower electricity consumption costs. The uniquely efficient design also improves the life of this motor, thereby reducing potential down time and refitting costs. The product meets the IE4 and IE5 efficiency class at every operating speeds, making it one of the most efficient electric motors available in the European market. This is ahead of the mandatory efficiency requirements set by the European Union, currently for IE3 motors.

RANGE OF PRODUCTS

A range of solutions to meet specific demand:

- **Combined package motor/drive** (HPC series), **Integral construction motor/drive** (HPI series) or **stand-alone motor** (HPS series)
- **IPM** (Interior Permanent Magnets) or **SMPM** (Surface Mounted Permanent Magnets) **design**, depending on the performance demand
- Super Premium Efficiency **IE4** or Ultra Premium Efficiency **IE5**
- IEC Mechanical configurations (B14, B5, etc.) and NEMA mounting

DIFFERENT MOTOR DESIGN DEPENDING ON THE PERFORMANCE DEMAND

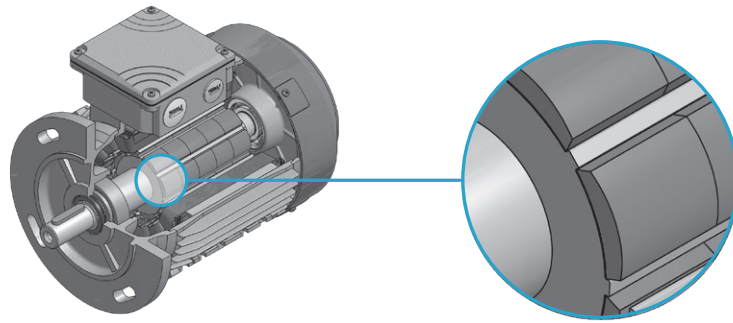

SMPM Design
Surface Mounted Permanent Magnets

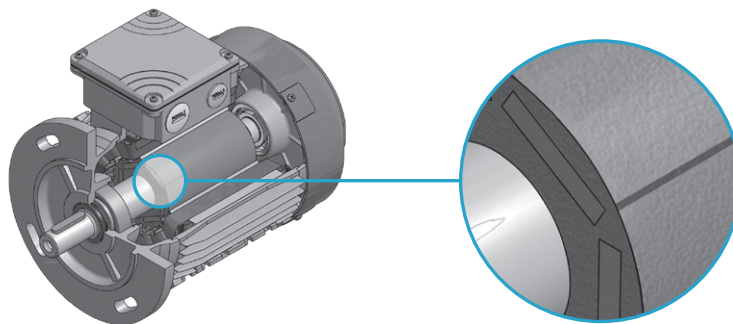

IPM Design
Interior Permanent Magnets

SAVING ENERGY WITH HP COMBI & INTEGRAL

Electric motors have a significant impact on the worldwide energy consumption:

→ up to 75% in industrial application and 40% in commercial application*

Today, a major factor influencing the motor industry is energy efficiency driven by both increasingly demanding legislation and the industry's greater awareness of environmental responsibility.

Lafert embraces the challenge! With HP Combi & Integral, saving energy and reducing costs are possible with three easy steps:

1. INCREASED MOTOR EFFICIENCY
2. SPEED CONTROL BY A VFD
3. SYSTEM OPTIMISATION

* Source: International Energy Agency

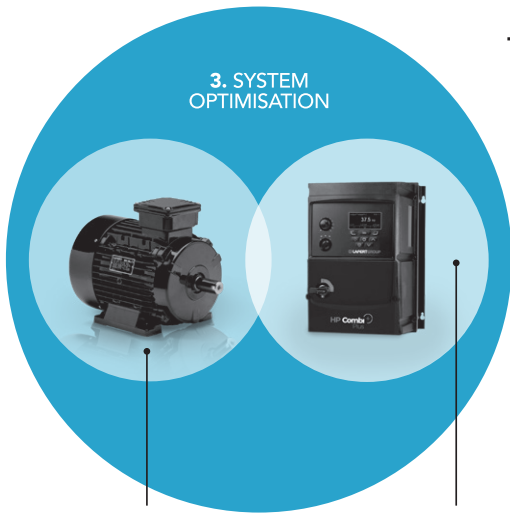

1. INCREASED MOTOR EFFICIENCY

2. SPEED CONTROL BY VFD



1. INCREASED MOTOR EFFICIENCY

PM (permanent magnet) Synchronous Motors offer improved electrical efficiency when compared to traditional AC motors, achieving IE4 and IE5 efficiency levels.

PM technology benefits:

- HIGH EFFICIENCY ACROSS A WIDE RANGE OF OPERATING SPEEDS
- EXCELLENT POWER DENSITY AND TORQUE CAPABILITY

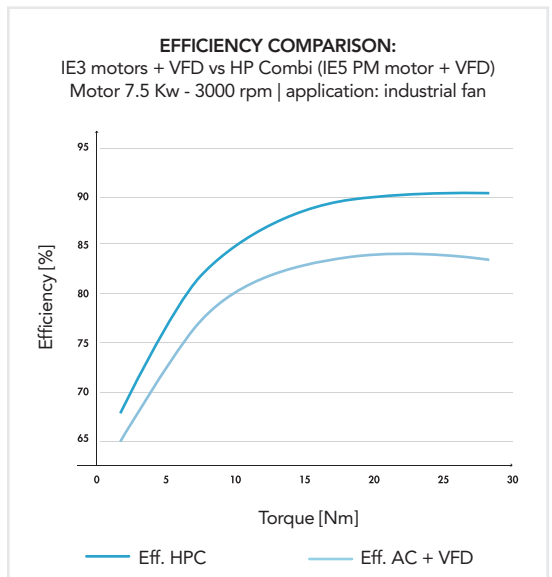

2. SPEED CONTROL BY VFD

A Variable Frequency Drive (VFD) is used to adjust the speed and torque of motor according to the variable demand of an application.

This results in a **relevant decrease in energy consumption** that leads to a **remarkable improvement in overall process efficiency**.

70% of applications are suitable for speed control. Typical variable torque applications, like **fans, compressors and pumps**, will benefit considerably from speed control:

SPEED REDUCTION OF 20% RESULTS IN UP TO 50% ENERGY REDUCTION



3. SYSTEM OPTIMISATION

The motor-drive system is **fully dimensioned and configured in accordance with the application's needs** and the customer's requirements.

Each motor-drive system is unique and designed for the purpose.

This results in a **PLUG & PLAY solution**, with a wide range of optimised motor-drive configurations for **fast set-up and easy commissioning**.

One single source for both system's components, motor and drive, makes this possible!

TECHNICAL DESCRIPTION

BRIEF DESCRIPTION

The following features of our HP Motors may vary depending on series and type:

- Admissible environmental temperature: from -15 °C up to +40 °C, with altitudes 1000 m above sea level
- Mounting: IM B3, B5, B14, B34, B35
- Flange concentricity degree "N"; balancing: vibration "A/B"; dynamic balancing with half key
- Shaft designed according to the standard version with key (also available without key)
- Available speeds: 1500, 1800, 3000, 3600, 4500 rpm (others on request)
- Drive operating voltage: 230 or 400 Vac
- Insulation class: "F"; temperature rise to class B (TEFC execution)
- IP55 degree of protection for the whole range
- On-Off PTO switch for thermal protection (NTC and PTC are available)
- Optional feedback on request: resolver, encoder, tacho and Hall sensors (several combinations may be added to this list)
- Reduced dimensions
- Permanent magnets technology

DEFINITIONS

- **HPS:** High Performance Stand alone motors to be controlled by a separate drive (SENSORLESS)
- **HPC:** High Performance Combined drive motors
- **HPI:** High Performance Integral drive motors
- **Rated torque (Mn):** Torque available on the shaft continuously (service S1) with rated speed and with a winding current equivalent to the rated current, holding the motor in rated working condition.
- **Peak torque (Mpk):** Torque available on the shaft discontinuously, with a winding current equivalent to the peak current.
- **Rated current (In):** Current supplied to the motor continuously at a rated speed, required to develop rated torque.
- **Peak current (Ipk):** Current supplied to the motor discontinuously within a wide range of speed, required to develop peak torque without exceed the thermal class of motor.
- **Voltage constant (Ke):** Ratio between voltage induced by the rotor rotation (RMS value for sinusoidal motor, peak value for trapezoidal motor) at a certain number of revolutions and angular speed ($\omega = 2 \times \pi \times n / 60$ where n is the speed expressed in rpm) measured in rad/sec.
- **Torque constant (Kt):** Ratio between torque on the shaft and the current RMS value for sinusoidal motors, peak value for trapezoidal motors (equivalent to the voltage constant of a trapezoidal motor and to that of a sinusoidal motor multiplied by $\sqrt{3}$).
- **Back electromotive force (B.E.M.F):** Voltage induced by the rotor rotation (RMS value for sinusoidal motor, peak value for trapezoidal motor) at a certain number of revolutions.

QUALITY SYSTEM CERTIFICATE



The strictness of our quality control assures the flawless operation and reliability of our products. Our quality is confirmed by the **Certificate ISO 9001:2015** awarded by KIWA-CERMET, a certification body authorized by ACCREDIA.

SAFETY STANDARDS

Our motors comply with the requirements of the International Standard **IEC 60034** for rotating electrical machines as well as with the following European Directives: **Low Voltage Directive (LV) 2014/35/EC**, **Electromagnetic Compatibility Directive (EMC) 2014/30/EC**.

All products comply with the requirements of the **Directive Machines (MD) 2006/42/EC**. In accordance with this Directive, induction motors are components and intended solely for integration into other machines. Commissioning is forbidden until conformity of the end-product with this Directive is proved.



The CE marking was applied for the first time in 1995.

When operating the motor, the observance of the Regulation EN 60204-1 and safety instructions indicated in our Operating Instructions must be complied with.

Motors and Drives complied with many other international standards are available on request:



Motors and Drives approved by UL Underwriters Laboratories Inc.



HPI approved by ETL.



Motors and Drives complied with all applicable UK legislative requirements (UK Conformity Assessed).

EFFICIENCY STANDARDS

The HPS motors comply with:

IEC TS 60034-30-2: Rotating electrical machines - Part 30-2: Efficiency classes of variable speed AC motors (IE-code).

GB 30253-13: Minimum allowable values of energy efficiency and energy efficiency grades for permanent magnet synchronous motors - **CEL – China Energy Label:** Level 2 grade efficiency.

HPC/HPI motors comply with:

IEC 61800-9-1: Adjustable speed electrical power drive systems - Part 9-1: Ecodesign for power drive systems, motor starters, power electronics and their driven applications - General requirements for setting energy efficiency standards for power driven equipment using the extended product approach (EPA) and semi analytic model (SAM).

IEC 61800-9-2: Adjustable speed electrical power drive systems - Part 9-2: Ecodesign for power drive systems, motor starters, power electronics and their driven applications - Energy efficiency indicators for power drive systems and motor starters.



STANDARDS AND REGULATIONS

	EFFICIENCY TESTING METHOD	EFFICIENCY CLASSIFICATION	IE CODE						
			IEC STANDARD		EU MEPS	HP INTEGRAL			
MOTOR	IEC 60034-2-3	IEC 60034-30-2	IE1	IE2	IE3	IE4	IE5	IE3	IE5
VFD	IEC 61800-9-2:VFD Classification and testing		IE0	IE1	IE2			IE2	IE2
MOTOR + VFD	IEC 61800-9-2:VFD Classification and testing		IE50	IE51	IE52				IE52

INTERNATIONAL STANDARD IEC 60034-30-2:2016

IE4 IE5

Motor efficiencies are harmonized to the **International Standard IEC 60034-30-2:2016** that extends the efficiency levels to Super Premium Efficiency IE4 and IE5.

Output kW	IE4 REFERENCE LIMIT				IE5 REFERENCE LIMIT			
	Rated speed within 600 to 900 /min	Rated speed within 901 to 1200 /min	Rated speed within 1201 to 1800 /min	Rated speed within 1801 to 6000 /min	Rated speed within 600 to 900 /min	Rated speed within 901 to 1200 /min	Rated speed within 1201 to 1800 /min	Rated speed within 1801 to 6000 /min
0.12	62.3	64.9	69.8	66.5	67.4	69.8	74.3	71.4
0.18	67.2	70.1	74.7	70.8	71.9	74.6	78.7	75.2
0.2	68.4	71.4	75.8	71.9	73	75.7	79.6	76.2
0.25	70.8	74.1	77.9	74.3	75.2	78.1	81.5	78.3
0.37	74.3	78	81.1	78.1	78.4	81.6	84.3	81.7
0.4	74.9	78.7	81.7	78.9	78.9	82.2	84.8	82.3
0.55	77	80.9	83.9	81.5	80.6	84.2	86.7	84.6
0.75	78.4	82.7	85.7	83.5	82	85.7	88.2	86.3
1.1	80.8	84.5	87.2	85.2	84	87.2	89.5	87.8
1.5	82.6	85.9	88.2	86.5	85.5	88.4	90.4	88.9
2.2	84.5	87.4	89.5	88	87.2	89.7	91.4	90.2
3	85.9	88.6	90.4	89.1	88.4	90.6	92.1	91.1
4	87.1	89.5	91.1	90	89.4	91.4	92.8	91.8
5.5	88.3	90.5	91.9	90.9	90.4	92.2	93.4	92.6
7.5	89.3	91.3	92.6	91.7	91.3	92.9	94	93.3
11	90.4	92.3	93.3	92.6	92.2	93.7	94.6	94
15	91.2	92.9	93.9	93.3	92.9	94.3	95.1	94.5
18.5	91.7	93.4	94.2	93.7	93.3	94.6	95.3	94.9
22	92.1	93.7	94.5	94	93.6	94.9	95.5	95.1
30	92.7	94.2	94.9	94.5	94.1	95.3	95.9	95.5
37	93.1	94.5	95.2	94.8	94.4	95.6	96.1	95.8
45	93.4	94.8	95.4	95	94.7	95.8	96.3	96
55	93.7	95.1	95.7	95.3	94.9	96	96.5	96.2
75	94.2	95.4	96	95.6	95.3	96.3	96.7	96.5
90	94.4	95.6	96.1	95.8	95.5	96.5	96.9	96.6
110	94.7	95.8	96.3	96	95.7	96.6	97	96.8
132	94.9	96	96.4	96.2	95.9	96.8	97.1	96.9

For the nominal efficiency calculation refer to the IEC 60034-30-2:2016.

VARIABLE FREQUENCY DRIVES (VFDs) EFFICIENCY

Our entire HP Combi range of VFDs exceed the IE2 requirements of the Ecodesign Directive.

The **Ecodesign Directive EU 2019/1781** establishes, across the EU, a framework for setting eco-design requirements for energy-related products. It is a key instrument of EU policy for improving the energy efficiency and other aspects of the environmental performance of products placed on the market.

The regulation came into force in October 2019 and includes variable frequency drives (VFDs) together with a wide range of electric motors. A second phase, which expands the scope of the regulation and increases the requirements for motors, will come into effect on 1st July 2023.

How does this affect variable frequency drives?

The latest Ecodesign Directive introduces International Efficiency (IE) classes for certain variable frequency drives. **From 1st July 2021, specified VFDs must meet IE2 specification.** Our HP Combi drive range already meet these requirements. New requirements for drive support information.

From 1st July 2021, support information for every drive covered by this directive must include its IE class and year of manufacture. VFD manufacturers must also provide power losses in terms of percentage of rated apparent output power at eight different operating points, as well as standby losses and apparent percentage power loss at various operating points.

What does IE2 mean for VFDs?

The regulation covers three-phase standard drives with a diode rectifier in the range $0,12 \text{ kW} \leq P_n < 1000 \text{ kW}$. After 1st July 2021, the power losses of these drives shall not exceed the maximum power losses corresponding to the IE2 efficiency level. The efficiency level is given at the nominal point.

HP Combi drive range by Lafert is built to exceed the requirements of IE2 as required by the Ecodesign Directive.

Find the energy efficiency data for your VFD simply entering the relevant part no. into the dedicated tool in our website under the HP Combi product page.



OTHER STANDARDS

HPS/HPC/HPI units comply with the relevant standards and regulations, especially:

ELECTRONICAL	Safety requirements - Electrical, thermal and energy	IEC 61800-5-1
	EMC requirements and specific test methods	IEC 61800-3
	Ecodesign for power drive systems, motor starters, power electronics and their driven applications	IEC 61800-9-1
	Ecodesign for power drive systems, motor starters, power electronics and their driven applications	IEC 61800-9-2
	Energy efficiency indicators for power drive systems and motor starters	
Safety of machinery - Electrical equipment of machines - Part 1: General requirements		IEC 60204-1
ELECTRICAL	Rating and performance	IEC 60034-1
	Efficiency classes of variable speed AC Motors (IE-CODE)	IEC 60034-30-2
	Terminal markings and direction of rotation of rotating electrical machines	IEC 60034-8
	Selection of Energy-efficient motors including variable speed applications-application guide	IEC/ST 60034-31
	Insulating materials	IEC 60085
MECHANICAL	Dimensions and output ratings	IEC 60072
	Mounting dimensions and relationship frame sizes-output ratings, IM B3, IM B5, IM B14	IEC 60072
	Cylindrical shaft ends for electric motors	IEC 60072
	Degrees of protection	IEC 60034-5
	Methods of cooling	IEC 60034-6
	Mounting arrangements	IEC 60034-7
	Mechanical vibration	IEC 60034-14
	Mounting flanges	DIN 42948
	Tolerances of mounting and shaft extensions	DIN 42955
	Classification of environmental conditions	IEC 60721-2-1
	Mechanical vibration; balancing	ISO 8821

COMPLIANCE WITH EMC DIRECTIVE 2014/30/EU

In the great majority of cases, HPC/HPI Drive is used by professionals of the trade as a complex component forming part of a larger appliance, system or installation. It must be noted that the responsibility for the final EMC properties of the appliance, system or installation rests with the installer.

EMC GENERAL STANDARDS

The product standards are stated in **EN 61800-3** (IEC 61800-3): adjustable speed electrical power drive systems-Part 3. EMC product standard including specific test methods.

HPC/HPI Motors comply with:

EN 61800-3, unrestricted distribution¹⁾

EN 61800-3, restricted distribution

Residential, commercial and light industrial environment: EN 61000-6-3²⁾, EN 61000-6-1

Industrial environment: EN 61000-6-2, EN 61000-6-4

¹⁾ Emission levels stated by EN 61800-3 unrestricted distribution are only fulfilled by HPI Motors with class B-1 filter.

²⁾ Emission levels stated by EN 61000-6-3 are only fulfilled by HPI Motors with class B-1 optional filter.

EMC IMMUNITY

If there are problems with low frequency interference (ground loops), screened cable used for bus, standard bus, control cables and signal interface can be left open at one end.

BASIC STANDARDS

EMISSIONS

EN 55011: Limits and methods of measuring radio disturbance characteristics of industrial, scientific and medical (ISM) radio-frequency equipment

EN 55022: Limits and methods of measuring radio disturbance characteristics of information technology equipment

EN 61000-3-2: Limits for harmonic current emissions (equipment input current ≤ 16 A)

EN 61000-3-12: Limits for harmonic current emissions (equipment input current >16 A)

EN 61000-6-4: Electromagnetic compatibility (EMC)-Part 6-4, Generic standards-Emission standard for industrial environments

EN 61000-6-3¹⁾: Residential, commercial and light industrial environment

1) Emission levels stated by EN 61000-6-3 are only fulfilled by HPI Motors with class B-1 optional filter.

IMMUNITY

EN 61000-2-4 (IEC 61000-2-4): Compatibility levels Simulation of voltage and frequency fluctuations, harmonics and commutation notches on the power line

EN 61000-4-2 (IEC 61000-4-2): Electrostatic discharge (ESD) Simulation of electrostatic discharge

EN 61000-4-4 (IEC 61000-4-4): Fast transients, burst 5/50 nS Simulation of transients caused by switching of contactors, relays or similar devices

EN 61000-4-5 (IEC 61000-4-5): Surges 1.2/50 μ S. Simulation of transients caused by e.g. lightning that strikes near an installation

EN 61000-4-3 (IEC 61000-4-3): Radio-frequency electromagnetic field. Amplitude modulated. Simulation of interference caused by radio transmission equipment

EN 61000-4-6 (IEC 61000-4-6): RF common mode. Simulation of the effect from radio-transmitting equipment connected to connection cables

ENV 50204: Radio-frequency electromagnetic field. Pulse modulated. Simulation of interference caused by GSM mobile phones. General aspects of EMC emissions for high frequency shielding, screened cables used for CanBus or RS485, standard bus, control cables and signal interface must in general be connected to the enclosure at both ends

EN 61000-6-2: Electromagnetic compatibility (EMC)-Part 6-2: Generic standards-Immunity for industrial environments

EN 61000-6-1: Residential, commercial and light industrial environment

VIBRATION AND SHOCK

HPS/HPC/HPI Motors have been tested according to a procedure based on the following standards:

- IEC 60068-2-6: Vibration (sinusoidal) - 1970
- IEC 60068-2-34: Random vibration broad-band- general requirements
- IEC 60068-2-35: Random vibration broad-band- high reproducibility
- IEC 60068-2-36: Random vibration broad-band- medium reproducibility

HPS/HPC/HPI Motors comply with requirements that correspond to conditions in the standards mentioned above.

AIR HUMIDITY

HPS/HPC/HPI Motors have been designed to meet the IEC 60068-2-3 standard, EN 50178 item 9.4.2.2/DIN 40040, class E, at 40°C.

Cyclic damp heat according to IEC 60068-2-30, 40°C.

AGGRESSIVE ENVIRONMENTS

In common with all electronic equipment HPC/HPI drive contains a large number of mechanical and electronic components, all of which are vulnerable to environmental effects to some extent.

Therefore the drive should not be installed in environments with airborne liquids, particles or gases capable of affecting and damaging the electronic components.

Failure to take the necessary protective measures increases the risk of stoppages, thus reducing the life of the drive. Damp and moisture can be carried through the air and condense in the drive. In addition to this, damp and moisture may cause corrosion of components and metal parts.

Steam, oil and salt water may cause corrosion of components and metal parts.

In environments with high temperatures and humidity, corrosive gases such as sulphur, nitrogen and chlorine compounds will cause chemical processes on the drive converter components.

Such chemical reactions will rapidly affect and damage the electronic components.

Mounting drive in aggressive environments will increase the risk of stoppages and furthermore considerably reduce the life of electronic converter.

Before the installation, the ambient air should be checked for damp and moisture, particles and gases. This may be done by observing existing installations in this environment. Typical indicators of harmful airborne damp and moisture are water or oil on metal parts, or corrosion of metal parts.

Excessive dust particle levels are often found on installation cabinets and existing electrical installations.

One indicator of aggressive airborne gases is blackening of copper rails and cable ends on existing installations.

CONDITIONS OF INSTALLATION

ELECTRICAL TOLERANCES

For industrial motors to **EN 60034-1**, certain tolerances must be allowed on guaranteed values, taking into consideration the necessary tolerances for the manufacture of such motors and the materials used. The standard includes the following remarks:

1- It is not intended that guarantees necessarily have to be given for all or any of the items involved. Quotations including guaranteed values subject to tolerances should say so, and the tolerances should be in accordance with the table.

2- Attention is drawn to the different interpretation of the term guarantee. In some countries a distinction is made between guaranteed values and typical or declared values.

3- Where a tolerance is stated in only one direction, the value is not limited in the other direction.

Values for	Tolerance
Efficiency (η) (by indirect determination)	- 0.15 (1 - η) at $P_N \leq 150$ kW - 0.1 (1 - η) at $P_N > 150$ kW
Power factor ($\cos \varphi$)	$\frac{1 - \cos \varphi}{6}$, minimum 0.02, maximum 0.07
Rated current with rated torque and revolutions (measurement in S1 duty cycle at rated speed with $\vartheta_{amb} \leq 40$ °C and altitude ≤ 1000 m above sea level)	In +/- 5%
Back electromotive force: Bemf	Bemf +/- 5%
Peak torque (M_K)	- 10 % of the guaranteed value (after allowing for this tolerance, M_K/M_N not less than 1.6)
Moment of inertia (J)	± 10 % of the guaranteed value

MECHANICAL TOLERANCES

Motors have to be installed according to their mounting arrangements defined by **IEC 60034-7**, Code I (in brackets Code II). The mechanical components may be designed in order to work as for the motor mounting code.

According to **IEC 60072-1**, the following tolerances on mechanical dimensions of electric motors are permitted:

Parameter	Code	Tolerance	
Shaft height	H	- up to 132	-0.5 mm
Diameter of shaft end¹⁾	D	- from 11 to 28 mm	j6
		- from 38 to 48 mm	k6
Hub key width	F		h9
Flange spigot	N	- up to 132	j6
		- over size 132	h6

1) Centring holes in shaft extension to DIN 332 part 2

CONDITIONS OF INSTALLATION

THERMAL PROTECTION AND DERATING

HPS/HPC/HPI Motors are thermally protected in case limits are exceeded (140°C), another protection is provided through the drive.

DERATING FOR AMBIENT TEMPERATURE

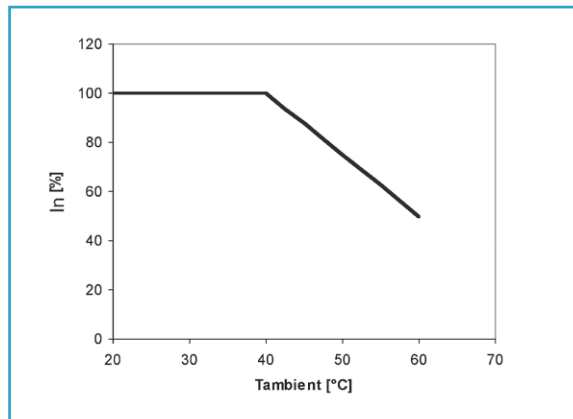

The ambient temperature (TAMAX) is the maximum temperature allowed. If Motor is operated at temperatures above 40 °C, a derating of the continuous output current is necessary.

DERATING FOR AIR PRESSURE

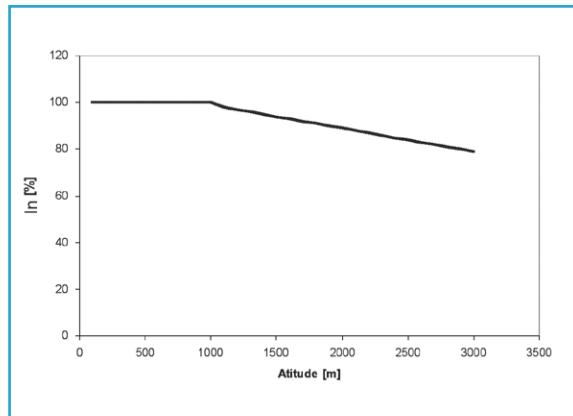

Below 1000 m altitude no derating is necessary. Above 1000 m the ambient temperature (TA) or max. rated output current (IN) must be derated in accordance with the following diagram.

See the below diagram for derating of output current versus altitude at TA = max. 40°C

DERATING FOR RUNNING AT LOW SPEED

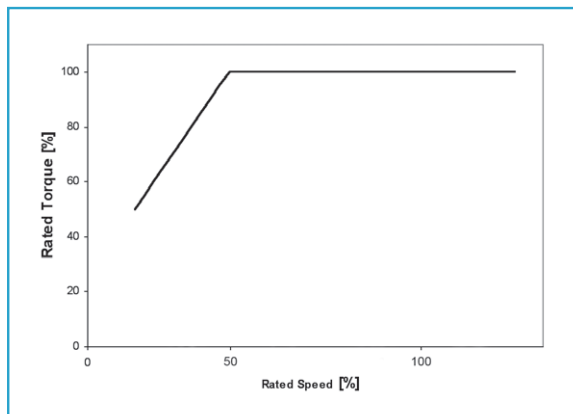

When a centrifugal pump or a fan is controlled by a Motor, it is not necessary to reduce the output at low speed because the load characteristic of the centrifugal pumps/fans, automatically ensures the necessary reduction.

Motors running constant load torque applications continuously at low speed must be derated (see diagram as example) or an independent fan must be used.

CONDITIONS OF INSTALLATION

HPS ELECTRICAL CONNECTION

The stand-alone HPS motor can NOT be installed directly on the mains. HPS motor needs always to be controlled by a drive.

The 3 phases from the drive needs to be connected to U1, V1, W1 (Please see DWG 1).

HPS motors covered in this catalogue are all related to 400V data, and are designed for one supply voltage. It is not possible to make star/delta connections in the terminal box like on an AC motor. HPS motor is in general 3*400V but can also be delivered for 3*230V.

Rotation direction: there are two ways to change the rotating direction of the HPS motor. First of all by changing the sequences of 2 phases from the drive or by having the drive to change the rotating direction via the software (Please see DWG 2).

Warning: please be aware that when turning the shaft and without any connection to the drive, the HPS motor will work as a generator and deliver a voltage level (BEMF Voltage) according to the rotating speed.

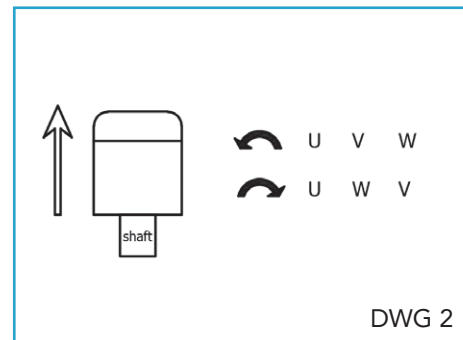
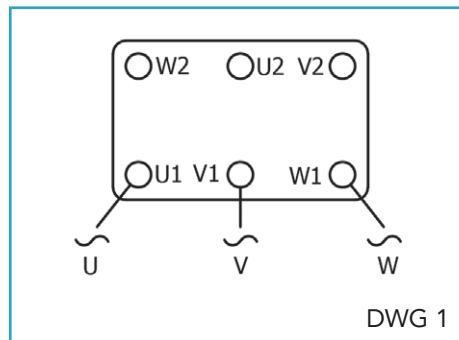

GALVANIC ISOLATION (PELV)

Galvanic (ensured) isolation is obtained by fulfilling requirements concerning higher isolation and by providing the relevant creepage/clearance distances. These requirements are described in the EN 50178 standard.

All control terminals are supplied from or in connection with extra low voltage (PELV).

The components that make up the electrical isolation, as described below, also comply with the requirements concerning higher isolation and the relevant test as described in EN 50178. The galvanic isolation can be shown in three locations (see drawing below), namely:

1. Power supply (SMPS) including signal isolation of VDCbus, indicating the intermediate voltage.
2. Gate drive that runs the IGBTs (opto couplers)
3. DCbus Voltage transducer (opto couplers)
4. Current transducers (Hall Effect-Based Current Sensor).

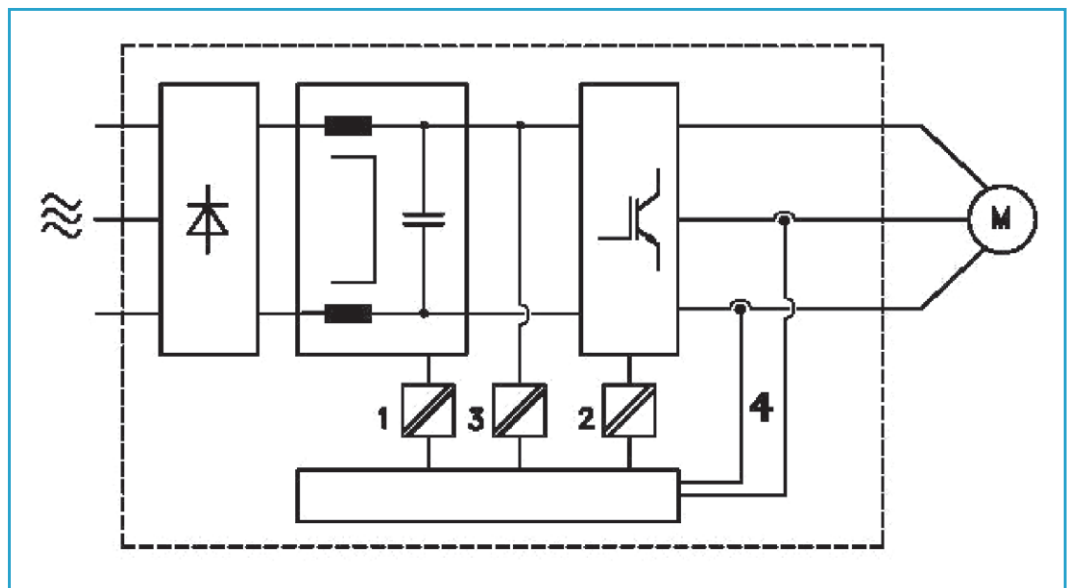

EARTH LEAKAGE CURRENT

Earth leakage current is primarily caused by the capacitance between motor phases and the motor frame. The RFI filter contributes additional leakage current, as the filter circuit is connected to earth through capacitors (C_y).

The size of the leakage current to the ground depends on the following factors, in order of priority:

- 1 - Switching PWM frequency
- 2 - Motor grounded on site or not

The leakage current is of importance to safety during handling/operation of the drive if (by mistake) the drive has not been earthed.

OVER VOLTAGE PROTECTION

The voltage in the intermediate circuit is increased when the motor acts as a generator. This occurs in two cases:

- 1 - The load generates energy.
- 2 - During deceleration ("ramp-down") if the moment of inertia is high, the load is low and the ramp-down time is too short for the energy to be dissipated as a loss in the HPI frequency converter, the motor and the installation.

The drive turns off to protect the IGBT transistors and the intermediate circuit capacitors when a certain voltage level is reached on DCbus.

MAINS SUPPLY INTERFERENCE/HARMONICS

An integral drive takes up a non-sinusoidal current from mains. A non-sinusoidal current can be transformed by means of a Fourier analysis and split up into sine wave currents with different frequencies, i.e. different harmonic currents IN with 50 Hz as the basic frequency.

Some of the harmonic currents might disturb communication equipment connected to the same transformer or cause resonance in connection with power-factor correction batteries.

To ensure low, harmonic currents, for the residential and commercial environments, an optional harmonic filter is necessary.

DEGREES OF PROTECTION

Degrees of mechanical protection for machines are designated in accordance with IEC 60034-5 by the letters IP and two characteristic numerals.

First numeral: Protection against contact and ingress of foreign bodies

Second numeral: Protection against ingress of water

IP	Description	IP	Description
0	No special protection	0	No special protection
1	Protection against solid foreign bodies larger than 50 mm (Example: inadvertent contact with the hand)	1	Protection against vertically falling water drops (condensation)
2	Protection against solid foreign bodies larger than 12 mm (Example: inadvertent contact with the fingers)	2	Protection against dropping water when inclined by up to 15°
3	Protection against solid foreign bodies larger than 2.5 mm (Example: Wires, tools)	3	Protection against waterspray at up to 60° from vertical
4	Protection against solid foreign bodies larger than 1 mm (Example: Wires, bands)	4	Protection against water splashed from any direction
5	Protection against dust (harmful deposits of dust)	5	Protection against water projected by a nozzle from any direction
6	Complete protection against dust	6	Protection against heavy seas or water projected in powerful jets

MOUNTING ARRANGEMENTS

Mounting arrangements for rotating electrical machines are designated according to IEC 60034-7, Code I (in brackets Code II).

Foot mounting

IM B3 (IM 1001)

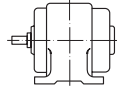

IM B6 (IM 1051)

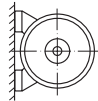

IM B7 (IM 1061)

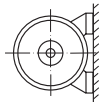

IM B8 (IM 1071)

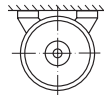

IM V5 (IM 1011)

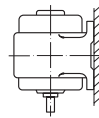

IM V6 (IM 1031)

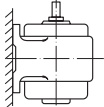

IM B34 (IM 2101)

Flange type C to
DIN 42 948 at
drive end

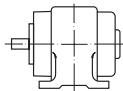

Flange mounting

IM B5 (IM 3001)

Flange type A to
DIN 42 948 at
drive end

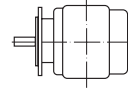

IM V1 (IM 3011)

Flange type A to
DIN 42 948 at
drive end

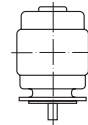

IM V3 (IM 3031)

Flange type A to
DIN 42 948 at
drive end

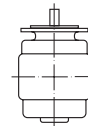

IM B35 (IM 2001)

Flange type A to
DIN 42 948 at
drive end

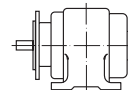

IM B14 (IM 3601)

Flange type C to
DIN 42 948 at
drive end

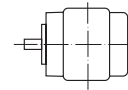

IM V18 (IM 3611)

Flange type C to
DIN 42 948 at
drive end

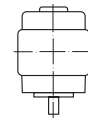

IM V19 (IM 3631)

Flange type C to
DIN 42 948 at
drive end



It is essential to state the desired mounting arrangement when ordering, as the constructive design depends partly on the mounting arrangement.

BEARING LUBRICATION AND MAINTENANCE

All motors have bearings type 2ZC3 with grease suitable for high and low temperature and permanent lubrication.

Frame size	Speed rpm	DE	NDE
56	Up to 4500	6202 2Z C3	6201 2Z C3
71	Up to 4500	6205 2Z C3	6303 2Z C3
90	Up to 4500	6206 2Z C3	6304 2Z C3
112	Up to 3600	6208 2Z C3	6306 2Z C3
132	Up to 3600	6309 2Z C3	6208 2Z C3
160	Up to 3600	6309 2Z C3	6309 2Z C3

PERMISSIBLE AXIAL FORCES

Maximum permissible axial forces with permissible radial forces*

Frame size	Horizontal shaft IM B3					Vertical shaft IM V1 force upwards**					Vertical shaft IM V1 force downwards				
	4500 rpm kN	3600 rpm kN	3000 rpm kN	1800 rpm kN	1500 rpm kN	4500 rpm kN	3600 rpm kN	3000 rpm kN	1800 rpm kN	1500 rpm kN	4500 rpm kN	3600 rpm kN	3000 rpm kN	1800 rpm kN	1500 rpm kN
56	0.07	0.07	0.09	0.13	0.13	0.26	0.27	0.28	0.31	0.31	0.06	0.07	0.08	0.12	0.12
71	0.09	0.13	0.16	0.28	0.33	0.39	0.39	0.41	0.50	0.54	0.07	0.11	0.15	0.26	0.31
90S-L	0.12	0.17	0.22	0.40	0.47	0.61	0.65	0.69	0.86	0.91	0.08	0.14	0.19	0.37	0.44
112M	-	0.36	0.41	0.49	0.49	-	0.77	0.78	0.98	0.98	-	0.26	0.33	0.40	0.40
112XL	-	0.34	0.41	0.49	0.49	-	0.62	0.68	0.76	0.76	-	0.24	0.31	0.39	0.39
132M	-	0.17	0.30	0.75	0.95	-	1.75	1.77	2.12	2.30	-	0.08	0.21	0.72	0.87
132XL	-	0.20	0.34	0.83	1.01	-	1.51	1.81	2.17	2.34	-	0.08	0.23	0.73	0.90
132XXL	-	0.20	0.35	0.84	1.02	-	1.65	1.79	2.33	2.83	-	0.07	0.22	0.71	0.89
160M	-	-	-	0.97	1.04	-	-	-	2.39	2.46	-	-	-	0.74	0.81
160L (22kW)	-	-	-	1.47	1.57	-	-	-	2.48	2.57	-	-	-	1.22	1.32
160L	-	0.90	0.96	1.39	1.47	-	1.95	2.01	2.43	2.50	-	0.62	0.68	1.11	1.20

Values for 50 Hz. For service on 60 Hz, reduce values by 10%

* Consult according to direction of force

** Consult technical office

PERMISSIBLE RADIAL FORCES

Without additional axial force (Ball bearings)

Nominal life= 20.000 h (Lh10)

FR= permissible radial force in kn in load point corresponding to half shaft extension

Frame size	4500 rpm kN	3600 rpm kN	3000 rpm kN	1800 rpm kN	1500 rpm kN
56	0.29	0.33	0.34	0.41	0.44
71	0.57	0.58	0.60	0.64	0.66
90 S-L	0.84	0.85	0.87	0.88	0.90
112 M	-	1.35	1.37	1.39	1.43
112 XL	-	1.37	1.40	1.42	1.45
132 M	-	2.50	2.55	2.59	2.60
132 XL	-	2.56	2.59	2.60	2.65
132 XXL	-	2.60	2.63	2.65	2.70
160M	-	-	-	2.40	2.70
160L (22kW)	-	-	-	2.70	3.00
160L	-	2.34	2.60	2.88	3.20

COOLING

TEFC execution as standard.
Surface cooling, independent of the direction of rotation.

VIBRATION

The amplitude of vibration in electric motors is governed by EN 60034-14 **Mechanical vibration of rotating electrical machines with shaft heights 56 and larger - methods of measurement and limits.**

Standard motors are designed to vibration grade A (normal). Vibration grade B is available at extra cost.

Rotors are at present dynamically balanced with **half** key fitted as per DIN ISO 8821. Other balancing only on request.

The motors are identified as follows:

"H" or "blank" means balanced with **half key**

"F" means balanced with **full key**

"N" means **no key**

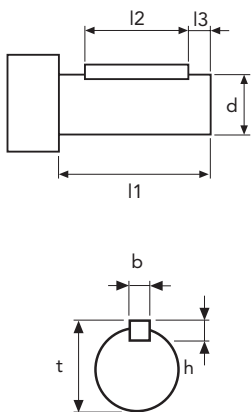

POSITION AND DIMENSIONS OF KEY

Frame size	d x l1	b x h	l2	l3	t
56	14 x 30	5 x 5	20	6	16
71	19 x 40	6 x 6	30	6	21.5
90	24 x 50	8 x 7	40	6	27
112	28 x 60	8 x 7	50	6	31
132	38 x 80	10 x 8	70	6	41
160	42x110	12 x 8	100	6	45

Dimensions in mm.

For larger shafts in special design the dimensions l2 and l3 are maintained.

NEMA MOUNTING



IEC size	NEMA size	Type C Face (B14)
71	56	✓
90	143/145	✓
112	182/184	✓
132	213/215	✓
160	254/256	✓

Foot mounting available with IEC shaft height and NEMA shaft and flange dimensions

MOTOR NAMEPLATE

NAMEPLATE EXAMPLE - HPS RANGE

LAFERT IES UK CA CE

Made in Italy 0522 L1

Type HPS 71 1800 16 3~Mot IEC 60034 N' SAMPLE

Ins.Cl. F	IP55	S 1 CONT	T.amb. -20...+40°C
	P=0.75 kW	In=1.6 A	
	Nn=1800min ⁻¹	f=90 Hz	
B.E.M.F.=291V	Mn=4.0Nm	Wt=5.4 Kg	T ₁ =86.7%
R _{f-f} =13.9 Ω	L _{f-f} =52.6mH	Ke=1.55 Vs	Kt=2.46 Nm/A

Drive Supply 400Vac

LAFERT S.p.A. Via J.F.Kennedy 43 - I - 30027 San Donà di Piave (VE)

NAMEPLATE EXAMPLE - VFD COMBI

LAFERTGROUP HP Combi Plus

Member of Sanborn Drive Technologies

Variable Frequency Drive
IP55 / NEMA 12 Indoor Use only www.lafert.com

XCP2-521-F1NMXX

Input	200-240V	50/60Hz	3Ph	29.1A	5.5kW /	IE2%
Output	0 - Vin	0-500Hz	3Ph	24.0A	7.5HP	2

Made in the UK
Max Amb, 40° C
SCCR: For rating and protection refer to User Guide

CAUTION

UK CA CE C UL US

Functional Safety TÜV Rheinland FS EAC

Listed 2AD0 Ind. Cont. Eq. E226333

Serial No.: 1111111111 S/W : V3.09 13042021

LAFERTGROUP HP Combi Smart

Member of Sanborn Drive Technologies

Variable Frequency Drive
IP66 / NEMA 4X www.lafert.com

XCS3-12A-F0ASXX

Input	200-240V	50/60Hz	1Ph	7.5A	0.75 kW /	IE2%
Output	0 - Vin	0-500Hz	3Ph	2.3A	1 HP	2

Made in the UK
Max Amb, 40° C
SCCR: For rating and protection refer to User Guide

CAUTION

Risk of Electric Shock
Power down for 10 minutes before removing cover. Read User Guide before installation or servicing.

AVERTISSEMENT

Risque de choc électrique
Une Tension dangereuse peut être présente jusqu'à 10 mins avant coupe l'alimentation.

UK CA CE C UL US

Listed 2AD0 Ind. Cont. Eq. E226333

Serial No.: 1111111111 S/W : V3.09 15022021

NAMEPLATE EXAMPLE - VFD INTEGRAL

CE UK CA LAFERT S.p.A. Via J.F. Kennedy 43 I - 30027 San Donà di Piave (VE) **LAFERT**

P.N. xxxxxxxx-xxx N° 1234567-001 04 22 L1

Type: HPI 71 4500 1.1 32 200 B3

Input A	kW	Hp	S.F.	η	rpm
6.5-5.8	1.1	1.5	1.15	86.5%	4500

200-230V 3 Phase 50-60Hz
Class iECM 71 200
Over Current Device 6.1A
T.amb.40°C Weight=9.1Kg

Output: 0-100% Vin 0-7.5A Continuous Duty Ins.Cl.(ΔT)=F(B) TEFC

HPS - STAND ALONE MOTOR

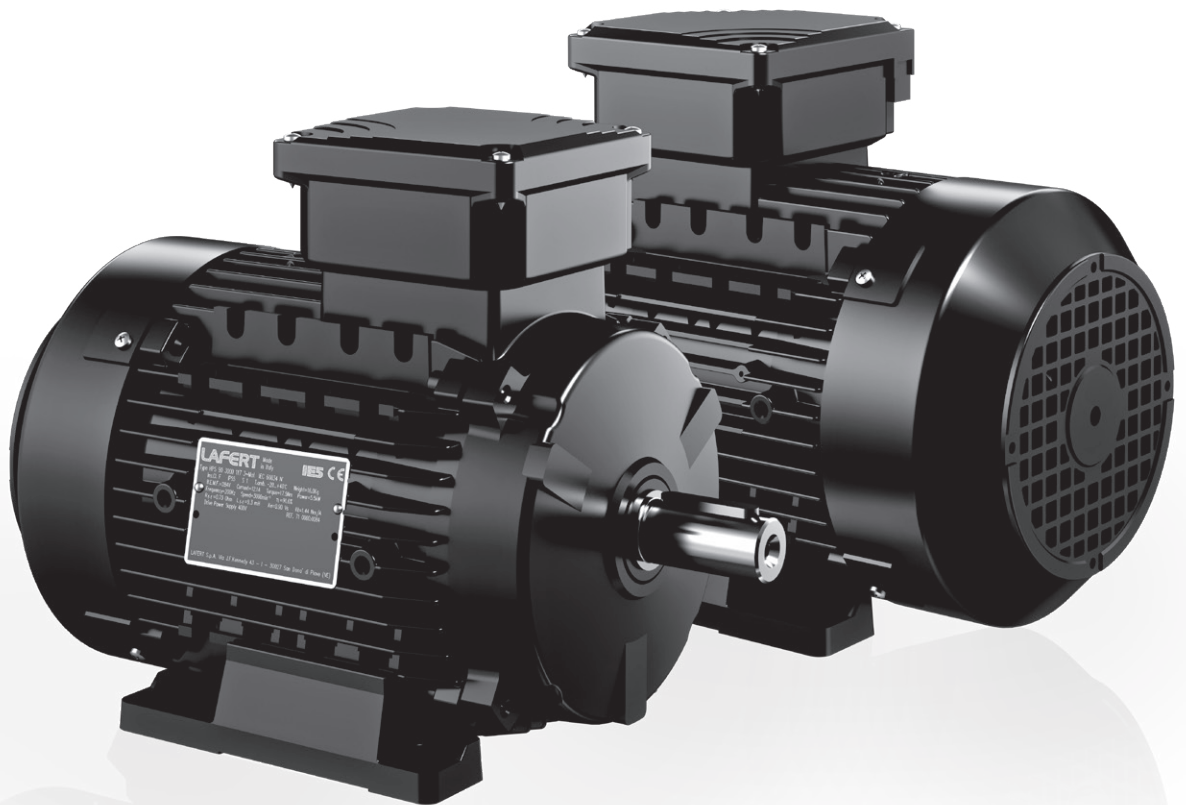

ULTRA PREMIUM EFFICIENCY - IE5

HPS - STAND ALONE MOTOR

1500 RPM

EFFICIENCY LEVEL ACCORDING TO IEC TS 60034-30-2:2016
DEGREE OF PROTECTION: IP55

IE5

VALUES @ 400 V

TEMPERATURE RISE TO CLASS B

Type	Size	Rated speed	Rated power	Rated torque	Peak torque	Voltage constant	Torque constant	BEMF at rated speed	Rated current	Nominal Efficiency* IE5	Weight
		n rpm	P _n kW	M _n Nm	M _{pk} Nm	K _e Vs	K _t Nm/A	E _n Vrs	I _n Arms	η %	Kg
1500 rpm											
HPS 56 1500 4	56	1500	0.18	1.2	3.4	1.73	3	272	0.4	76.3	3.0
HPS 56 1500 5	56	1500	0.25	1.6	4.8	1.73	3	272	0.5	79.3	3.2
HPS71 1500 12	71	1500	0.55	3.5	10.5	1.73	3	272	1.2	85.0	5.4
HPS71 1500 16	71	1500	0.75	4.8	14.4	1.73	3	272	1.6	86.7	6.2
HPS71 1500 23	71	1500	1.1	7.0	21.0	1.73	3	272	2.3	88.1	7.2
HPS90 1500 32	S-L	1500	1.5	9.6	28.7	1.73	3	272	3.2	89.1	14
HPS90 1500 47	S-L	1500	2.2	14.0	42.0	1.73	3	272	4.7	90.2	14
HPS90 1500 64	XL	1500	3	19.1	57.3	1.73	3	272	6.4	91.0	18
HPS90 1500 85	XL	1500	4	25.5	76.4	1.73	3	272	8.5	91.8	19
HPS112 1500 85	M	1500	4	25.5	76.4	1.73	3	272	8.5	91.8	26
HPS112 1500 117	M	1500	5.5	35.0	105.1	1.73	3	272	11.7	92.5	30
HPS112 1500 159	XL	1500	7.5	47.8	143.3	1.73	3	272	15.9	93.2	33
HPS112 1500 195	XL	1500	9.2	58.6	175.8	1.73	3	272	19.5	93.5	33
HPS132 1500 233	XL	1500	11	70.0	210.1	1.73	3	272	23.3	93.8	56
HPS132 1500 318	XXL	1500	15	95.5	286.5	1.73	3	272	31.8	94.4	65
HPS132 1500 393	XXL	1500	18.5	117.8	353.4	1.73	3	272	39.3	94.6	65
HPS160 1500 233	M	1500	11	70	175	1.73	3	272	23.3	93.8	70
HPS160 1500 318	M	1500	15	95	239	1.73	3	272	31.8	94.4	75
HPS160 1500 393	M	1500	18.5	118	294	1.73	3	272	39.3	94.6	85
HPS160 1500 467	L	1500	22	140	350	1.73	3	272	46.7	94.9	95
HPS160 1500 637	L	1500	30	191	477	1.73	3	272	63.7	95.3	115

* In new IEC TS 60034-30-2, the IE class limit values are reduced by adding the additional harmonic losses caused by the drive: 15% additional losses for motors up to 90 kW

ULTRA PREMIUM EFFICIENCY - IE5

HPS - STAND ALONE MOTOR

1800 RPM

EFFICIENCY LEVEL ACCORDING TO IEC TS 60034-30-2:2016
DEGREE OF PROTECTION: IP55

IE5

VALUES @ 400 V

TEMPERATURE RISE TO CLASS B

Type	Size	Rated speed	Rated power	Rated torque	Peak torque	Voltage constant	Torque constant	BEMF at rated speed	Rated current	Nominal Efficiency* IE5	Weight
		n rpm	P _n kW	M _n Nm	M _{pk} Nm	K _e Vs	K _t Nm/A	E _n Vrs	I _n Arms	η %	Kg
1800 rpm											
HPS 56 1800 4	56	1800	0.18	1.0	2.9	1.45	2.5	272	0.4	76.3	3.0
HPS 56 1800 5	56	1800	0.25	1.3	4.0	1.45	2.5	272	0.5	79.3	3.2
HPS71 1800 12	71	1800	0.55	2.9	8.8	1.45	2.5	272	1.2	85.0	5.0
HPS71 1800 16	71	1800	0.75	4.0	11.9	1.45	2.5	272	1.6	86.7	5.4
HPS71 1800 23	71	1800	1.1	5.8	17.5	1.45	2.5	272	2.3	88.1	7.0
HPS71 1800 32	71	1800	1.5	8.0	23.9	1.45	2.5	272	3.2	89.1	7.0
HPS90 1800 32	S-L	1800	1.5	8.0	23.9	1.45	2.5	272	3.2	89.1	12
HPS90 1800 46	S-L	1800	2.2	11.7	35.0	1.45	2.5	272	4.6	90.2	14
HPS90 1800 64	S-L	1800	3	15.9	47.7	1.45	2.5	272	6.3	91.0	17
HPS90 1800 84	XL	1800	4	21.2	63.7	1.45	2.5	272	8.4	91.8	18
HPS112 1800 84	M	1800	4	21.2	63.7	1.45	2.5	272	8.4	91.8	23
HPS112 1800 116	M	1800	5.5	29.2	87.5	1.45	2.5	272	11.6	92.5	23
HPS112 1800 158	M	1800	7.5	39.8	119.4	1.45	2.5	272	15.8	93.2	30
HPS112 1800 232	XL	1800	11	58.4	175.1	1.45	2.5	272	23.2	93.5	33
HPS132 1800 232	M	1800	11	58.4	175.1	1.45	2.5	272	23.2	93.8	54
HPS132 1800 317	XXL	1800	15	79.6	238.7	1.45	2.5	272	31.7	94.4	58
HPS132 1800 391	XXL	1800	18.5	98.1	294.4	1.45	2.5	272	39.1	94.6	65
HPS160 1800 232	M	1800	11	58	146	1.45	2.5	272	23.2	93.8	70
HPS160 1800 317	M	1800	15	80	199	1.45	2.5	272	31.7	94.4	75
HPS160 1800 391	M	1800	18.5	98	245	1.45	2.5	272	39.1	94.6	75
HPS160 1800 465	L	1800	22	117	292	1.45	2.5	272	46.5	94.9	85
HPS160 1800 634	L	1800	30	159	398	1.45	2.5	272	63.4	95.3	100

* In new IEC TS 60034-30-2, the IE class limit values are reduced by adding the additional harmonic losses caused by the drive: 15% additional losses for motors up to 90 kW

ULTRA PREMIUM EFFICIENCY - IE5

HPS - STAND ALONE MOTOR

3000 RPM

EFFICIENCY LEVEL ACCORDING TO IEC TS 60034-30-2:2016
DEGREE OF PROTECTION: IP55

IE5

VALUES @ 400 V

TEMPERATURE RISE TO CLASS B

Type	Size	Rated speed	Rated power	Rated torque	Peak torque	Voltage constant	Torque constant	BEMF at rated speed	Rated current	Nominal Efficiency* IE5	Weight
		n rpm	P _n kW	M _n Nm	M _{pk} Nm	K _e Vs	K _t Nm/A	E _n Vrs	I _n Arms	η %	Kg
3000 rpm											
HPS 56 3000 5	56	3000	0.25	0.8	2.4	0.87	1.5	272	0.5	75.8	2.8
HPS 56 3000 8	56	3000	0.37	1.2	3.5	0.87	1.5	272	0.8	79.5	3.0
HPS 56 3000 12	56	3000	0.55	1.8	5.3	0.87	1.5	272	1.2	82.7	3.2
HPS71 3000 16	71	3000	0.75	2.4	7.2	0.87	1.5	272	1.6	84.6	4.8
HPS71 3000 23	71	3000	1.1	3.5	10.5	0.87	1.5	272	2.3	86.2	6.0
HPS71 3000 32	71	3000	1.5	4.8	14.3	0.87	1.5	272	3.2	87.4	6.0
HPS71 3000 47	71	3000	2.2	7.0	21.0	0.87	1.5	272	4.7	88.9	6.6
HPS90 3000 47	S-L	3000	2.2	7.0	21.0	0.87	1.5	272	4.7	88.9	10
HPS90 3000 64	S-L	3000	3	9.6	28.7	0.87	1.5	272	6.4	89.9	12
HPS90 3000 85	S-L	3000	4	12.7	38.2	0.87	1.5	272	8.5	90.7	14
HPS90 3000 117	S-L	3000	5.5	17.5	52.5	0.87	1.5	272	11.7	91.6	16
HPS112 3000 117	M	3000	5.5	17.5	52.5	0.87	1.5	272	11.7	91.6	23
HPS112 3000 159	M	3000	7.5	23.9	71.6	0.87	1.5	272	15.9	92.4	26
HPS112 3000 233	M	3000	11	35.0	105.1	0.87	1.5	272	23.3	93.2	30
HPS112 3000 318	M	3000	15	47.8	143.3	0.87	1.5	272	31.8	93.7	33
HPS132 3000 318	M	3000	15	47.8	143.3	0.87	1.5	272	31.8	93.7	55
HPS132 3000 393	XL	3000	18.5	58.9	176.7	0.87	1.5	272	39.3	94.2	59
HPS132 3000 467	XXL	3000	22	70.0	210.1	0.87	1.5	272	46.7	94.4	67
HPS132 3000 636	XXL	3000	30	95.4	286.0	0.87	1.5	272	63.6	94.9	72
HPS160 3000 634	L	3000	30	95.4	239	0.87	1.5	272	63.4	94.9	90
HPS160 3000 782	L	3000	37	118.0	294	0.87	1.5	272	78.2	95.2	95

* In new IEC TS 60034-30-2, the IE class limit values are reduced by adding the additional harmonic losses caused by the drive: 15% additional losses for motors up to 90 kW

ULTRA PREMIUM EFFICIENCY - IE5

HPS - STAND ALONE MOTOR

3600 RPM

EFFICIENCY LEVEL ACCORDING TO IEC TS 60034-30-2:2016
DEGREE OF PROTECTION: IP55

IE5

VALUES @ 400 V

TEMPERATURE RISE TO CLASS B

Type	Size	Rated speed	Rated power	Rated torque	Peak torque	Voltage constant	Torque constant	BEMF at rated speed	Rated current	Nominal Efficiency* IE5	Weight
		n rpm	P _n kW	M _n Nm	M _{pk} Nm	K _e Vs	K _t Nm/A	E _n Vrs	I _n Arms	η %	Kg
3600 rpm											
HPS 56 3600 5	56	3600	0.25	0.7	2.0	0.73	1.26	272	0.5	75.8	2.8
HPS 56 3600 8	56	3600	0.37	1.0	2.9	0.73	1.26	272	0.8	79.5	3.0
HPS 56 3600 12	56	3600	0.55	1.5	4.4	0.73	1.26	272	1.2	82.7	3.2
HPS71 3600 16	71	3600	0.75	2.0	6.0	0.73	1.26	272	1.6	84.6	4.8
HPS71 3600 23	71	3600	1.1	2.9	8.8	0.73	1.26	272	2.3	86.2	6.0
HPS71 3600 32	71	3600	1.5	4.0	11.9	0.73	1.26	272	3.2	87.4	6.0
HPS71 3600 46	71	3600	2.2	5.8	17.5	0.73	1.26	272	4.6	88.9	6.6
HPS90 3600 46	S-L	3600	2.2	5.8	17.5	0.73	1.26	272	4.6	88.9	10
HPS90 3600 63	S-L	3600	3	8.0	23.9	0.73	1.26	272	6.3	89.9	12
HPS90 3600 84	S-L	3600	4	10.6	31.8	0.73	1.26	272	8.4	90.7	14
HPS90 3600 116	S-L	3600	5.5	14.6	43.8	0.73	1.26	272	11.6	91.6	16
HPS112 3600 116	M	3600	5.5	14.6	43.8	0.73	1.26	272	11.6	91.6	23
HPS112 3600 158	M	3600	7.5	19.9	59.7	0.73	1.26	272	15.8	92.4	26
HPS112 3600 232	M	3600	11	29.2	87.5	0.73	1.26	272	23.2	93.2	30
HPS112 3600 317	M	3600	15	39.8	119.4	0.73	1.26	272	31.7	93.7	33
HPS132 3600 317	M	3600	15	39.8	119.4	0.73	1.26	272	31.7	93.7	55
HPS132 3600 391	XL	3600	18.5	49.1	147.2	0.73	1.26	272	39.1	94.2	59
HPS132 3600 465	XXL	3600	22	58.4	175.1	0.73	1.26	272	46.5	94.4	67
HPS132 3600 634	XXL	3600	30	79.6	238.7	0.73	1.26	272	63.4	94.9	72
HPS160 3600 629	L	3600	30	79.6	199	0.73	1.26	272	62.9	94.9	85
HPS160 3600 776	L	3600	37	98.0	245	0.73	1.26	272	77.6	95.2	90

* In new IEC TS 60034-30-2, the IE class limit values are reduced by adding the additional harmonic losses caused by the drive: 15% additional losses for motors up to 90 kW

ULTRA PREMIUM EFFICIENCY - IE5

HPS - STAND ALONE MOTOR

4500 RPM

EFFICIENCY LEVEL ACCORDING TO IEC TS 60034-30-2:2016
DEGREE OF PROTECTION: IP55

IE5

VALUES @ 400 V

TEMPERATURE RISE TO CLASS B

Type	Size	Rated speed	Rated power	Rated torque	Peak torque	Voltage constant	Torque constant	BEMF at rated speed	Rated current	Nominal Efficiency* IE5	Weight
		n rpm	P _n kW	M _n Nm	M _{pk} Nm	K _e Vs	K _t Nm/A	E _n Vrs	I _n Arms	η %	Kg
4500 rpm											
HPS 56 4500 8	56	4500	0.37	0.8	2.4	0.58	1	272	0.8	79.5	3.0
HPS 56 4500 12	56	4500	0.55	1.2	3.5	0.58	1	272	1.2	82.7	3.0
HPS 56 4500 16	56	4500	0.75	1.6	4.8	0.58	1	272	1.6	84.6	3.2
HPS71 4500 23	71	4500	1.1	2.3	7.0	0.58	1	272	2.3	86.2	4.8
HPS71 4500 32	71	4500	1.5	3.2	9.6	0.58	1	272	3.2	87.4	5.4
HPS71 4500 47	71	4500	2.2	4.7	14.0	0.58	1	272	4.7	88.9	6.2
HPS71 4500 64	71	4500	3	6.4	19.1	0.58	1	272	6.4	89.9	7.2
HPS90 4500 64	S-L	4500	3	6.4	19.1	0.58	1	272	6.4	88.9	12
HPS90 4500 85	S-L	4500	4	8.5	25.5	0.58	1	272	8.5	90.7	14
HPS90 4500 117	S-L	4500	5.5	11.7	35.0	0.58	1	272	11.7	91.6	17
HPS90 4500 159	XL	4500	7.5	15.9	47.8	0.58	1	272	15.9	92.4	18

* In new IEC TS 60034-30-2, the IE class limit values are reduced by adding the additional harmonic losses caused by the drive: 15% additional losses for motors up to 90 kW

SUPER PREMIUM EFFICIENCY - IE4

HPS - STAND ALONE MOTOR

1500 RPM

EFFICIENCY LEVEL ACCORDING TO IEC TS 60034-30-2:2016
DEGREE OF PROTECTION: IP55

IE4

VALUES @ 400 V

TEMPERATURE RISE TO CLASS B

Type	Size	Rated speed	Rated power	Rated torque	Peak torque	Voltage constant	Torque constant	BEMF at rated speed	Rated current	Nominal Efficiency* IE4	Weight
		n rpm	P _n kW	M _n Nm	M _{pk} Nm	K _e Vs	K _t Nm/A	E _n Vrs	I _n Arms	η %	Kg
1500 rpm											
HPS 56 1500 4	56	1500	0.18	1.2	3.4	1.73	3	272	0.4	72.0	2.8
HPS 56 1500 5	56	1500	0.25	1.6	4.8	1.73	3	272	0.5	75.4	3.0
HPS 56 1500 8	56	1500	0.37	2.4	7.1	1.73	3	272	0.8	78.9	3.2
HPS71 1500 12	71	1500	0.55	3.5	10.5	1.73	3	272	1.2	81.9	4.8
HPS71 1500 16	71	1500	0.75	4.8	14.4	1.73	3	272	1.6	83.9	5.4
HPS71 1500 23	71	1500	1.1	7.0	21.0	1.73	3	272	2.3	85.6	6.2
HPS71 1500 32	71	1500	1.5	9.6	28.8	1.73	3	272	3.2	86.7	7.0
HPS90 1500 32	S-L	1500	1.5	9.6	28.7	1.73	3	272	3.2	86.7	10
HPS90 1500 47	S-L	1500	2.2	14.0	42.0	1.73	3	272	4.7	88.1	12
HPS90 1500 64	S-L	1500	3	19.1	57.3	1.73	3	272	6.4	89.1	14
HPS90 1500 85	XL	1500	4	25.5	76.4	1.73	3	272	8.5	89.9	17
HPS112 1500 85	M	1500	4	25.5	76.4	1.73	3	272	8.5	89.9	23
HPS112 1500 117	M	1500	5.5	35.0	105.1	1.73	3	272	11.7	90.8	26
HPS112 1500 159	M	1500	7.5	47.8	143.3	1.73	3	272	15.9	91.6	30
HPS112 1500 195	XL	1500	9.2	58.6	175.8	1.73	3	272	19.5	92.0	33
HPS132 1500 233	XL	1500	11	70.0	210.1	1.73	3	272	23.3	92.4	51
HPS132 1500 318	XXL	1500	15	95.5	286.5	1.73	3	272	31.8	93.0	58
HPS132 1500 393	XXL	1500	18.5	117.8	353.4	1.73	3	272	39.3	93.4	65
HPS160 1500 233	M	1500	11	70	175	1.73	3	272	23.3	92.4	65
HPS160 1500 318	M	1500	15	95	239	1.73	3	272	31.8	93.0	70
HPS160 1500 393	M	1500	18.5	118	294	1.73	3	272	39.3	93.4	80
HPS160 1500 467	L	1500	22	140	350	1.73	3	272	46.7	93.7	90
HPS160 1500 637	L	1500	30	191	477	1.73	3	272	63.7	94.2	110

* In new IEC TS 60034-30-2, the IE class limit values are reduced by adding the additional harmonic losses caused by the drive: 15% additional losses for motors up to 90 kW

SUPER PREMIUM EFFICIENCY - IE4

HPS - STAND ALONE MOTOR

1800 RPM

EFFICIENCY LEVEL ACCORDING TO IEC TS 60034-30-2:2016
DEGREE OF PROTECTION: IP55

IE4

VALUES @ 400 V

TEMPERATURE RISE TO CLASS B

Type	Size	Rated speed	Rated power	Rated torque	Peak torque	Voltage constant	Torque constant	BEMF at rated speed	Rated current	Nominal Efficiency* IE4	Weight
		n rpm	P _n kW	M _n Nm	M _{pk} Nm	K _e Vs	K _t Nm/A	E _n Vrs	I _n Arms	η %	Kg
1800 rpm											
HPS 56 1800 4	56	1800	0.18	1.0	2.9	1.45	2.5	272	0.4	72.0	2.8
HPS 56 1800 5	56	1800	0.25	1.3	4.0	1.45	2.5	272	0.5	75.4	3.0
HPS 56 1800 8	56	1800	0.37	2.0	5.9	1.45	2.5	272	0.8	78.9	3.2
HPS71 1800 12	71	1800	0.55	2.9	8.8	1.45	2.5	272	1.2	81.9	4.8
HPS71 1800 16	71	1800	0.75	4.0	11.9	1.45	2.5	272	1.6	83.9	5.4
HPS71 1800 23	71	1800	1.1	5.8	17.5	1.45	2.5	272	2.3	85.6	6.2
HPS71 1800 32	71	1800	1.5	8.0	23.9	1.45	2.5	272	3.2	86.7	7.0
HPS90 1800 32	S-L	1800	1.5	8.0	23.9	1.45	2.5	272	3.2	86.7	10
HPS90 1800 46	S-L	1800	2.2	11.7	35.0	1.45	2.5	272	4.6	88.1	12
HPS90 1800 64	S-L	1800	3	15.9	47.7	1.45	2.5	272	6.3	89.1	14
HPS90 1800 84	S-L	1800	4	21.2	63.7	1.45	2.5	272	8.4	89.9	17
HPS112 1800 84	M	1800	4	21.2	63.7	1.45	2.5	272	8.4	89.9	23
HPS112 1800 116	M	1800	5.5	29.2	87.5	1.45	2.5	272	11.6	90.8	26
HPS112 1800 158	M	1800	7.5	39.8	119.4	1.45	2.5	272	15.8	91.6	30
HPS112 1800 232	XL	1800	11	58.4	175.1	1.45	2.5	272	23.2	92.0	33
HPS132 1800 232	M	1800	11	58.4	175.1	1.45	2.5	272	23.2	92.4	51
HPS132 1800 317	XXL	1800	15	79.6	238.7	1.45	2.5	272	31.7	93.0	58
HPS132 1800 391	XXL	1800	18.5	98.1	294.4	1.45	2.5	272	39.1	93.4	65
HPS160 1800 232	M	1800	11	58	146	1.45	2.5	272	23.2	92.4	65
HPS160 1800 317	M	1800	15	80	199	1.45	2.5	272	31.7	93.0	70
HPS160 1800 391	M	1800	18.5	98	245	1.45	2.5	272	39.1	93.4	70
HPS160 1800 465	L	1800	22	117	292	1.45	2.5	272	46.5	93.7	80
HPS160 1800 634	L	1800	30	159	398	1.45	2.5	272	63.4	94.2	95

* In new IEC TS 60034-30-2, the IE class limit values are reduced by adding the additional harmonic losses caused by the drive: 15% additional losses for motors up to 90 kW

SUPER PREMIUM EFFICIENCY - IE4

HPS - STAND ALONE MOTOR

3000 RPM

EFFICIENCY LEVEL ACCORDING TO IEC TS 60034-30-2:2016
DEGREE OF PROTECTION: IP55

IE4

VALUES @ 400 V

TEMPERATURE RISE TO CLASS B

Type	Size	Rated speed	Rated power	Rated torque	Peak torque	Voltage constant	Torque constant	BEMF at rated speed	Rated current	Nominal Efficiency* IE4	Weight
		n rpm	P _n kW	M _n Nm	M _{pk} Nm	K _e Vs	K _t Nm/A	E _n Vrs	I _n Arms	η %	Kg
3000 rpm											
HPS56 3000 5	56	3000	0.25	0.8	2.4	0.87	1.5	272	0.5	71.5	2.6
HPS56 3000 8	56	3000	0.37	1.2	3.5	0.87	1.5	272	0.8	75.6	2.6
HPS56 3000 12	56	3000	0.55	1.8	5.3	0.87	1.5	272	1.2	79.3	2.8
HPS56 3000 16	56	3000	0.75	2.4	7.2	0.87	1.5	272	1.6	81.5	3.0
HPS71 3000 16	71	3000	0.75	2.4	7.2	0.87	1.5	272	1.6	81.5	4.8
HPS71 3000 23	71	3000	1.1	3.5	10.5	0.87	1.5	272	2.3	83.3	5.4
HPS71 3000 32	71	3000	1.5	4.8	14.3	0.87	1.5	272	3.2	84.8	6.0
HPS71 3000 47	71	3000	2.2	7.0	21.0	0.87	1.5	272	4.7	86.4	6.6
HPS90 3000 47	S-L	3000	2.2	7.0	21.0	0.87	1.5	272	4.7	86.4	10
HPS90 3000 64	S-L	3000	3	9.6	28.7	0.87	1.5	272	6.4	87.7	12
HPS90 3000 85	S-L	3000	4	12.7	38.2	0.87	1.5	272	8.5	88.7	14
HPS90 3000 117	S-L	3000	5.5	17.5	52.5	0.87	1.5	272	11.7	89.7	16
HPS112 3000 117	M	3000	5.5	17.5	52.5	0.87	1.5	272	11.7	89.7	23
HPS112 3000 159	M	3000	7.5	23.9	71.6	0.87	1.5	272	15.9	90.6	26
HPS112 3000 233	M	3000	11	35.0	105.1	0.87	1.5	272	23.3	91.6	30
HPS112 3000 318	M	3000	15	47.8	143.3	0.87	1.5	272	31.8	92.4	33
HPS132 3000 318	M	3000	15	47.8	143.3	0.87	1.5	272	31.8	92.4	51
HPS132 3000 393	XL	3000	18.5	58.9	176.7	0.87	1.5	272	39.3	92.8	58
HPS132 3000 467	XXL	3000	22	70.0	210.1	0.87	1.5	272	46.7	93.2	65
HPS132 3000 636	XXL	3000	30	95.4	286.0	0.87	1.5	272	63.6	93.7	72
HPS160 3000 634	L	3000	30	95.4	239	0.87	1.5	272	63.4	93.7	85
HPS160 3000 782	L	3000	37	118.0	294	0.87	1.5	272	78.2	94.1	90

* In new IEC TS 60034-30-2, the IE class limit values are reduced by adding the additional harmonic losses caused by the drive: 15% additional losses for motors up to 90 kW

SUPER PREMIUM EFFICIENCY - IE4

HPS - STAND ALONE MOTOR

3600 RPM

EFFICIENCY LEVEL ACCORDING TO IEC TS 60034-30-2:2016
DEGREE OF PROTECTION: IP55

IE4

VALUES @ 400 V

TEMPERATURE RISE TO CLASS B

Type	Size	Rated speed	Rated power	Rated torque	Peak torque	Voltage constant	Torque constant	BEMF at rated speed	Rated current	Nominal Efficiency* IE4	Weight
		n rpm	P _n kW	M _n Nm	M _{pk} Nm	K _e Vs	K _t Nm/A	E _n Vrs	I _n Arms	η %	Kg
3600 rpm											
HPS 56 3600 5	56	3600	0.25	0.7	2.0	0.73	1.26	272	0.5	71.5	2.6
HPS 56 3600 8	56	3600	0.37	1.0	2.9	0.73	1.26	272	0.8	75.6	2.6
HPS 56 3600 12	56	3600	0.55	1.5	4.4	0.73	1.26	272	1.2	79.3	2.8
HPS 56 3600 16	56	3600	0.75	2.0	6.0	0.73	1.26	272	1.6	81.5	3.0
HPS71 3600 16	71	3600	0.75	2.0	6.0	0.73	1.26	272	1.6	81.5	4.8
HPS71 3600 23	71	3600	1.1	2.9	8.8	0.73	1.26	272	2.3	83.3	5.4
HPS71 3600 32	71	3600	1.5	4.0	11.9	0.73	1.26	272	3.2	84.8	6.0
HPS71 3600 46	71	3600	2.2	5.8	17.5	0.73	1.26	272	4.6	86.4	6.6
HPS90 3600 46	S-L	3600	2.2	5.8	17.5	0.73	1.26	272	4.6	86.4	10
HPS90 3600 63	S-L	3600	3	8.0	23.9	0.73	1.26	272	6.3	87.7	12
HPS90 3600 84	S-L	3600	4	10.6	31.8	0.73	1.26	272	8.4	88.7	14
HPS90 3600 116	S-L	3600	5.5	14.6	43.8	0.73	1.26	272	11.6	89.7	16
HPS112 3600 116	M	3600	5.5	14.6	43.8	0.73	1.26	272	11.6	89.7	23
HPS112 3600 158	M	3600	7.5	19.9	59.7	0.73	1.26	272	15.8	90.6	26
HPS112 3600 232	M	3600	11	29.2	87.5	0.73	1.26	272	23.2	91.6	30
HPS112 3600 317	M	3600	15	39.8	119.4	0.73	1.26	272	31.7	92.4	33
HPS132 3600 317	M	3600	15	39.8	119.4	0.73	1.26	272	31.7	92.4	51
HPS132 3600 391	XL	3600	18.5	49.1	147.2	0.73	1.26	272	39.1	92.8	58
HPS132 3600 465	XXL	3600	22	58.4	175.1	0.73	1.26	272	46.5	93.2	65
HPS132 3600 634	XXL	3600	30	79.6	238.7	0.73	1.26	272	63.4	93.7	72
HPS160 3600 629	L	3600	30	79.6	199	0.73	1.26	272	62.9	93.7	80
HPS160 3600 776	L	3600	37	98.0	245	0.73	1.26	272	77.6	94.1	85

* In new IEC TS 60034-30-2, the IE class limit values are reduced by adding the additional harmonic losses caused by the drive: 15% additional losses for motors up to 90 kW

SUPER PREMIUM EFFICIENCY - IE4

HPS - STAND ALONE MOTOR

4500 RPM

EFFICIENCY LEVEL ACCORDING TO IEC TS 60034-30-2:2016
DEGREE OF PROTECTION: IP55

IE4

VALUES @ 400 V

TEMPERATURE RISE TO CLASS B

Type	Size	Rated speed	Rated power	Rated torque	Peak torque	Voltage constant	Torque constant	BEMF at rated speed	Rated current	Nominal Efficiency* IE4	Weight
		n rpm	P _n kW	M _n Nm	M _{pk} Nm	K _e Vs	K _t Nm/A	E _n Vrs	I _n Arms	η %	Kg
4500 rpm											
HPS 56 4500 8	56	4500	0.37	0.8	2.4	0.58	1	272	0.8	75.6	2.6
HPS 56 4500 12	56	4500	0.55	1.2	3.5	0.58	1	272	1.2	79.3	2.6
HPS 56 4500 16	56	4500	0.75	1.6	4.8	0.58	1	272	1.6	81.5	2.8
HPS 56 4500 23	56	4500	1.1	2.3	7.0	0.58	1	272	2.3	83.3	3.0
HPS71 4500 23	71	4500	1.1	2.3	7.0	0.58	1	272	2.3	83.3	4.8
HPS71 4500 32	71	4500	1.5	3.2	9.6	0.58	1	272	3.2	84.8	5.4
HPS71 4500 47	71	4500	2.2	4.7	14.0	0.58	1	272	4.7	86.4	6.2
HPS71 4500 64	71	4500	3	6.4	19.1	0.58	1	272	6.4	87.7	7.0
HPS90 4500 64	S-L	4500	3	6.4	19.1	0.58	1	272	6.4	87.7	10
HPS90 4500 85	S-L	4500	4	8.5	25.5	0.58	1	272	8.5	88.7	12
HPS90 4500 117	S-L	4500	5.5	11.7	35.0	0.58	1	272	11.7	89.7	14
HPS90 4500 159	S-L	4500	7.5	15.9	47.8	0.58	1	272	15.9	90.6	17

* In new IEC TS 60034-30-2, the IE class limit values are reduced by adding the additional harmonic losses caused by the drive: 15% additional losses for motors up to 90 kW

HPS FRAME SIZE 56 - 160 IM B3 ALUMINIUM ALLOY FRAME

ONLY FOR SIZE 90L

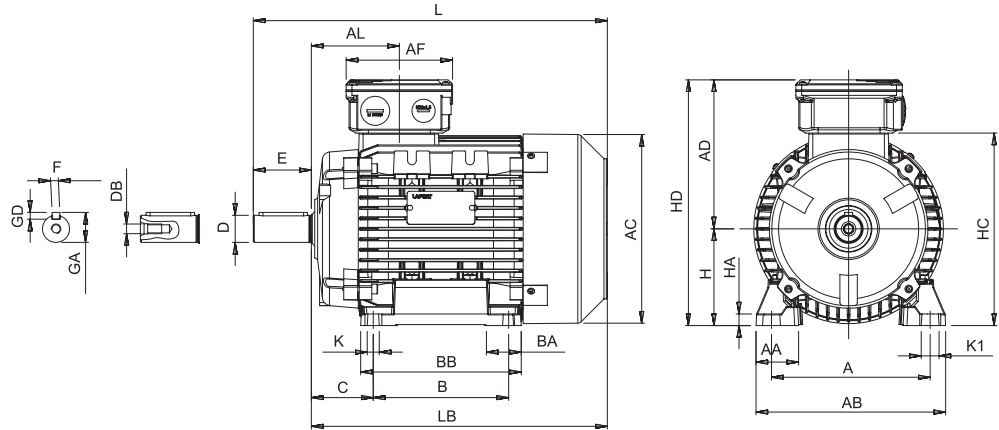
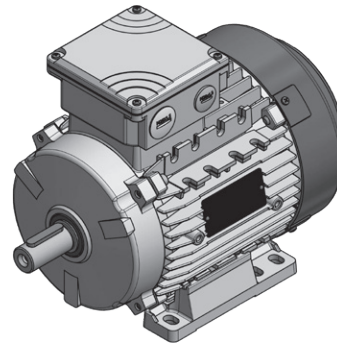
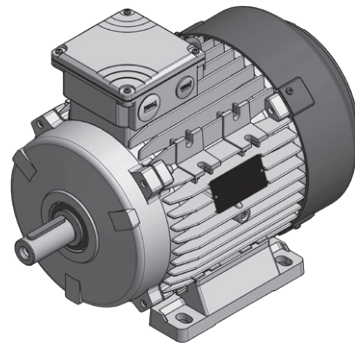

IEC	H	A	B	C	K ¹⁾	AB	BB	AD ²⁾	HD ²⁾	AC	HC	HA
56	56	90	71	36	6	107	86	92	148	110	109	8
71	71	112	90	45	8	135	108	114	185	142	142	9
90S	90	140	100	56	10	170	150	148	238	177	181	11
90L	90	140	125	56	10	170	150	148	238	177	181	11
90XL	90	140	125	56	10	170	150	148	238	177	181	11
112M	112	190	140	70	12.5	220	176	171	283	225	226	15
112XL	112	190	140	70	12.5	220	176	171	283	225	226	15
132M	132	216	178	89	12	256	218	195	327	248	261	17
132XL	132	216	178	89	12	256	218	195	327	248	261	17
132XXL	132	216	178	89	12	256	218	195	327	248	261	17
160M	160	254	210	108	14	320	270	238	398	317	316	23
160L	160	254	254	108	14	320	310	238	398	317	316	23

IEC	K1	L	LB	AL	AF	BA	AA	D	E	F	GD	GA	DB ³⁾
56	9	188	168	61	93	27	27	14	30	5	5	16	M5
71	17	245	215	75	93	22	30	19	40	6	6	22	M6
90S	15	317	267	85	110	28/53	37	24	50	8	7	27	M8
90L	15	317	267	85	110	28/53	37	24	50	8	7	27	M8
90XL	15	340	290	85	110	28/53	37	24	50	8	7	27	M8
112M	19	388	328	92	110	46	48	28	60	8	7	31	M10
112XL	19	410	350	92	110	46	48	28	60	8	7	31	M10
132M	20	485	405	122	137	45	59	38	80	10	8	41	M12
132XL	20	505	425	122	137	45	59	38	80	10	8	41	M12
132XXL	20	556	476	122	137	45	59	38	80	10	8	41	M12
160M	18	608	498	146	155	65	76	42*	110	12*	8*	45*	M16
160L	18	652	542	168	155	65	76	48	110	14	9	51.5	M16

1) Clearance hole for screw 2) Maximum dimension 3) Centering holes in shaft extensions to DIN 332 part 2

* For type HPS 160M 18.5kW, please refer to HPS 160L

HPS FRAME SIZE 56 - 160 IM B14, IM B5 ALUMINIUM ALLOY FRAME

IM B14

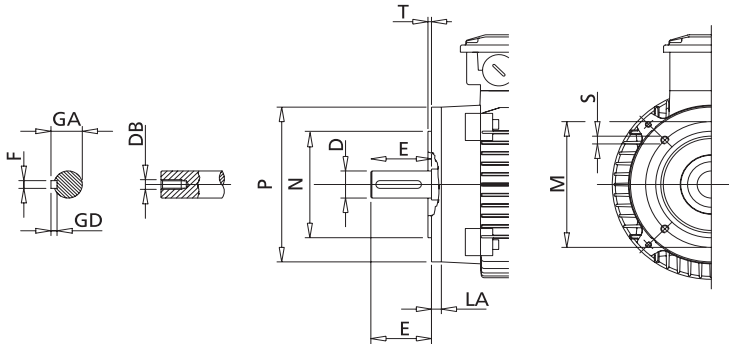

IM B5

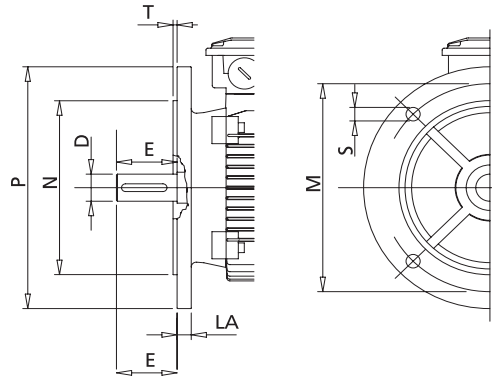

IEC	SMALL FLANGE B14						LARGE FLANGE B14						FLANGE B5					
	P	N	LA	M	T	S ¹⁾	P	N	LA	M	T	S ¹⁾	M	N	P	T	LA	S ¹⁾
56	80	50	8	65	2.5	M5	105	70	8	85	2.5	M6	100	80	120	2.5	7	M6
71	105	70	11	85	2.5	M6	140	95	8	115	3	M8	130	110	160	3.5	10	M8
90S-L	140	95	10	115	3	M8	160	110	9	130	3.5	M8	165	130	200	3.5	12	M10
112M-XL	160	110	10	130	3.5	M8	200	130	12	165	3.5	M10	215	180	250	4	14	M12
132M-XL-XXL	200	130	23	165	3.5	M10	250	180	12	215	4	M12	265	230	300	4	14	M12
160M-L	250	180	20	216	4	M12	300	230	12	265	5	M16	300	250	350	5	15	M16

1) Clearance hole for screw

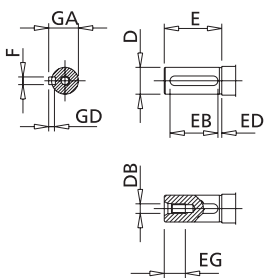

IEC	D	E	F h9	GD	GA	DB	EG	EB	ED
56	14	30	5	5	16	M5	12.5	20	4
71	19 j6	40	6	6	22	M6	16	30	4
90S-L	24 j6	50	8	7	27	M8	19	40	4
112M-XL	28 j6	60	8	7	31	M10	22	50	4
132M-XL-XXL	38 k6	80	10	8	41	M12	28	70	4
160M	42 k6*	110	12*	8*	45*	M16	36	100	4
160L	48k6*	110	14	9	51.5	M16	36	100	4

1) Centring holes in shaft extension to DIN 332 part 2

HP Combi

Smart  Flow  Plus 

solutions to meet your needs





RANGE OVERVIEW

HP Combi is a highly efficient motor-drive package that combines a **PM (permanent magnet) synchronous motor with the matched VFD (Variable Frequency Drive)**, achieving very **High Efficiency** levels.

The motor range leverages both brushless servo motor and AC induction motor technologies, so enhancing the power density and allowing for significant **size and weight reductions up to 50%**.

Several drive configurations are available to cover a wide range of industrial and commercial applications. In fact, HP Combi is targeted to both **variable torque applications**, typically in HVAC, as well as to **constant torque applications** like material handling, air compressors and vacuum pumps.

HP Combi is **Plug & Play**: preconfigured motor-drive solutions designed for easy set up and increased system efficiency.

PRODUCT LINE	FEATURES	THREE-PHASE SUPPLY VOLTAGE	POWER RATINGS	TORQUE		MAIN APPLICATIONS
				CONSTANT	VARIABLE	
	<ul style="list-style-type: none"> • Smart configuration • Suitable for most applications • Industrial, Pump & Fan modes 	200-240 V ± 10%	0.55 to 11 kW 0.75 to 15 HP	✓	✓	<ul style="list-style-type: none"> • General Industrial • HVAC
		380-480 V ± 10%	0.55 to 22 kW 0.75 to 30 HP			
	<ul style="list-style-type: none"> • Dedicated control functions for HVAC • Innovative energy saving features • Built-in PLC capability 	200-240 V ± 10%	0.55 to 22 kW 0.75 to 30 HP			<ul style="list-style-type: none"> • Advanced HVAC
		380-480 V ± 10%	0.55 to 37 kW 0.75 to 50 HP			
		500-600 V ± 10%	0.55 to 37 kW 0.75 to 50 HP			
	<ul style="list-style-type: none"> • Advanced configuration • Maximum performance, motor control • Built-in PLC capability • Flexible functionality 	200-240 V ± 10%	0.55 to 18.5 kW 0.75 to 25 HP	✓	✓	<ul style="list-style-type: none"> • Demanding Industrial • Compressors • Vacuum pumps • Material handling
		380-480 V ± 10%	0.55 to 37 kW 0.75 to 50 HP			
		500-600 V ± 10%	0.55 to 37 kW 0.75 to 50 HP			



MAIN SUPPLY			
Supply Frequency	48-62 Hz	48-62Hz	48-62Hz
Three-phase Supply Voltage	200-240 V ± 10%	200-240 V ± 10%	200-240 V ± 10%
	380-480 V ± 10%	380-480 V ± 10%	380-480 V ± 10%
		500-600 V ± 10%	500-600 V ± 10%
OUTPUT RATINGS			
Power Ratings	Up to 22 kW	Up to 37 kW	Up to 37 kW
Overload Capacity	150% for 60 seconds	110% for 60 seconds	150% for 60 seconds
	175% for 2.5 seconds	165% for 4 seconds	200% for 4 seconds
PROGRAMMABLE INPUTS			
	2 Digital	3 Digital (+3 optional)	3 Digital (+3 optional)
	2 Analog / Digital selectable	2 Analog / Digital selectable	2 Analog / Digital selectable
PROGRAMMABLE OUTPUTS			
	1 Analog / Digital	2 Analog / Digital	2 Analog / Digital
	1 Relay	2 Relays (+3 optional)	2 Relays (+3 optional)
BUILT IN FIELDBUS			
	CANopen	BACnet MS/TP	CANopen
	Modbus RTU	Modbus RTU	Modbus RTU
	Other options available	Other options available	Other options available
INTERNAL EMC FILTER			
	✓	✓*	✓*
INTERNAL BRAKE TRANSISTOR			
	✓**	NA	✓
BUILT-IN KEYPAD			
	✓	✓	✓
DISPLAY			
	7 segment LED	TFT multi-language text	TFT multi-language text
ENCLOSURE			
	Switched or non-switched	With or without disconnecter	Switched or non-switched
PI(D) CONTROL			
	Internal PI controller	Internal PID controller	Internal PID controller
	Standby / sleep function	STO function	STO function
		Programmable PLC	Programmable PLC
		Multi setpoint select	Multi setpoint select
		Standby / sleep function	Standby / sleep function

* Not available for 500-600V drives ** Not available in size 1

SAFE TORQUE OFF (PROVIDED AS STANDARD)

HPC Flow and Plus feature a safe torque off function to allow simple integration into machine critical safety circuits.









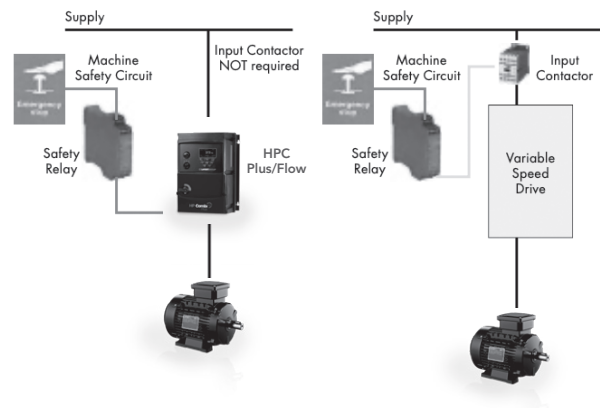

- Simple machine design reduces component costs, saves panel space and minimises installation time
- Faster shut down and reset procedures reduce system maintenance time
- Better safety standard compared to mechanical solution
- Better motor connection. Single cable with no interruption.



WITH

WITHOUT



TYPE	DESCRIPTION	Smart 	Flow 	Plus+ 
COMMUNICATION INTERFACES	 EtherCAT Plug in Interface Module		✓	✓
	 Profibus DPV-1 Plug in Interface Module		✓	✓
	 Profibus External Gateway & Cables	✓	✓	✓
	 Profinet IO Plug in Interface Module		✓	✓
	 EthernetIP Plug in Interface Module		✓	✓
	 EtherNet Module	✓	✓	✓
	 DeviceNet Plug in Interface Module		✓	✓
	 DeviceNET External Gateway & Cables	✓	✓	✓
COMMUNICATION OPTIONS	HP Drive Stick with Bluetooth Interface	✓	✓	✓
	USB PC Connection Kit	✓	✓	✓
I/O OPTIONS	Cascade Control Plug in Option Module		✓	✓
	Extended I/O Plug in Option Module		✓	✓
PLC LICENCE	HP Drive Tools PLC Function Single PC Licence			✓

HP Drive TOOLS



HP DRIVE TOOLS FOR PC

- Plain language descriptions with range and units
- Notes and advice concerning related parameters
- Parameter upload/download from VFD & electronic storage
- Print parameter set with changed parameters highlighted
- Multi-drive network support with one convenient connection
- Ghost parameters for ease of use or security
- Lock drive parameters to prevent user tampering
- Powerful scope function for commissioning and analysis
- Optional function block PLC
- PLC program protection to prevent unauthorized copying
- Connection via USB to RJ45 or HP Drive Stick



HP DRIVE TOOLS FOR MOBILE

- Mobile app available for iOS and Android
- Wireless drive commissioning using
- HP Drive stick
- Parameter file creation, upload, download & Storage
- Changed parameter highlighting
- Offline parameter file management
- Mobile to mobile parameter file sharing

HPC - COMBINED MOTOR & DRIVE

1500 RPM

EFFICIENCY LEVEL ACCORDING TO IEC 61800-9-2:VFD
 DEGREE OF PROTECTION: MOTOR IP55, VFD SIZE 1 TO 4 IP66, VFD SIZE 5 IP55

IES2 IP66

VALUES @ 400 V

Package Type	HPS IE5 MOTOR											IE2 DRIVE			IES2 COMBI		
	Size	Rated Speed	Rated Power	Rated Torque	Peak Torque	Voltage Constant	Torque Constant	Bemf @ rated speed	Rated Current	Efficiency	Weight	Smart	Flow	Plus	Smart	Flow	Plus
		n [rpm]	Pn [kW]	Mn [Nm]	Mpk [Nm]	ke [Vs]	kt [Nm/A]	En [Vrs]	In [Arms]	η [%]	[kg]	Size	Size	Size	η [%]	η [%]	η [%]
HPC 56	56	1500	0.18	1.2	3.4	1.73	3.0	272	0.4	76.3	3.0	1	2	2	74.3	75.0	73.6
	56	1500	0.25	1.6	4.8	1.73	3.0	272	0.5	79.3	3.2	1	2	2	77.2	77.9	76.5
HPC 71	71	1500	0.55	3.5	9.6	1.73	3.0	272	1.2	85.0	5.4	1	2	2	82.7	83.4	82.1
	71	1500	0.75	4.8	14.0	1.73	3.0	272	1.6	86.7	6.2	1	2	2	84.3	85.1	83.6
	71	1500	1.1	7.0	21.0	1.73	3.0	272	2.3	88.1	7.2	2	2	2	86.7	86.9	86.6
HPC 90	90 S-L	1500	1.5	9.6	28.7	1.73	3.0	272	3.2	89.1	14	2	2	2	88.3	88.5	87.6
	90 S-L	1500	2.2	14.0	42.0	1.73	3.0	272	4.7	90.2	14	2	2	2	89.7	89.4	88.7
	90 XL	1500	3	19.1	57.3	1.73	3.0	272	6.4	91.0	18	2	2	2	90.4	90.1	90.2
	90 XL	1500	4	25.5	76.4	1.73	3.0	272	8.5	91.8	19	2	2	2	91.3	90.8	90.7
HPC 112	112 M	1500	4	25.5	76.4	1.73	3.0	272	8.5	91.8	26	2	2	2	90.2	90.8	90.7
	112 M	1500	5.5	35.0	105.1	1.73	3.0	272	11.7	92.5	30	3	2	3	92.0	92.2	91.5
	112 XL	1500	7.5	47.8	143.3	1.73	3.0	272	15.9	93.2	33	3	3	3	92.7	92.8	92.0
	112 XL	1500	9.2	58.6	175.8	1.73	3.0	272	19.5	93.5	33	3	3	3	93.0	92.5	92.0
HPC 132	132 XL	1500	11	70.0	210.1	1.73	3.0	272	23.3	93.8	56	3	3	3	93.3	92.8	92.3
	132 XXL	1500	15	95.5	286.5	1.73	3.0	272	31.8	94.4	65	4	3	4	94.2	93.4	93.0
	132 XXL	1500	18.5	117.8	353.4	1.73	3.0	272	39.3	94.6	65	4	4	4	94.3	94.1	93.1
HPC 160	160 M	1500	11	70.0	175	1.73	3.0	272	23.3	93.8	70	3	3	3	93.3	92.8	92.3
	160 M	1500	15	95.0	239	1.73	3.0	272	31.8	94.4	75	4	3	4	94.2	93.4	93.0
	160 M	1500	18.5	118.0	294	1.73	3.0	272	39.3	94.6	85	4	4	4	94.3	94.1	93.1
	160 L	1500	22	140.0	350	1.73	3.0	272	46.7	94.9	95	4	4	5	94.6	94.4	94.4
	160 L	1500	30	191.0	477	1.73	2.5	272	63.7	95.3	115	NA	5	5	NA	94.9	94.7

HPC - COMBINED MOTOR & DRIVE

1800 RPM

EFFICIENCY LEVEL ACCORDING TO IEC 61800-9-2:VFD
 DEGREE OF PROTECTION: MOTOR IP55, VFD SIZE 1 TO 4 IP66, VFD SIZE 5 IP55

IES2 IP66

VALUES @ 400 V

Package Type	HPS IE5 MOTOR											IE2 DRIVE			IES2 COMBI		
	Size	Rated Speed	Rated Power	Rated Torque	Peak Torque	Voltage Constant	Torque Constant	Bemf @ rated speed	Rated Current	Efficiency	Weight	Smart	Flow	Plus	Smart	Flow	Plus
		n [rpm]	Pn [kW]	Mn [Nm]	Mpk [Nm]	ke [Vs]	kt [Nm/A]	En [Vrs]	In [Arms]	η [%]	[kg]	Size	Size	Size	η [%]	η [%]	η [%]
HPC 56	56	1800	0.18	1.0	2.9	1.45	2.5	272	0.4	76.3	3.0	1	2	2	74.7	75.4	74.0
	56	1800	0.25	1.3	4.0	1.45	2.5	272	0.5	79.3	3.2	1	2	2	77.6	78.3	76.9
HPC 71	71	1800	0.55	2.9	8.8	1.45	2.5	272	1.2	85.0	5.0	1	2	2	83.1	83.8	82.5
	71	1800	0.75	4.0	11.9	1.45	2.5	272	1.6	86.7	5.4	1	2	2	84.8	85.6	84.0
	71	1800	1.1	5.8	17.5	1.45	2.5	272	2.3	88.1	7.0	2	2	2	87.1	87.4	87.0
	71	1800	1.5	8.0	23.9	1.45	2.5	272	3.2	89.1	7.0	2	2	2	88.0	88.9	88.0
HPC 90	90 S-L	1800	1.5	8.0	23.9	1.45	2.5	272	3.2	89.1	12	2	2	2	88.7	88.9	88.0
	90 S-L	1800	2.2	11.7	35.0	1.45	2.5	272	4.6	90.2	14	2	2	2	89.9	89.6	89.0
	90 S-L	1800	3	15.9	47.7	1.45	2.5	272	6.3	91.0	17	2	2	2	90.6	90.3	90.4
	90 XL	1800	4	21.2	63.7	1.45	2.5	272	8.4	91.8	18	2	2	2	91.4	90.9	90.8
HPC 112	112 M	1800	4	21.2	63.7	1.45	2.5	272	8.4	91.8	23	2	2	2	91.4	90.9	90.8
	112 M	1800	5.5	29.2	87.5	1.45	2.5	272	11.6	92.5	23	3	2	3	92.1	92.4	91.6
	112 M	1800	7.5	39.8	119.4	1.45	2.5	272	15.8	93.2	30	3	3	3	92.9	92.9	92.2
	112 XL	1800	11	58.4	175.1	1.45	2.5	272	23.2	93.5	33	3	3	3	93.5	92.9	92.5
HPC 132	132 M	1800	11	58.4	175.1	1.45	2.5	272	23.2	93.8	54	3	3	3	93.8	93.2	92.7
	132 XXL	1800	15	79.6	238.7	1.45	2.5	272	31.7	94.4	58	4	3	4	94.7	93.9	93.4
	132 XXL	1800	18.5	98.1	294.4	1.45	2.5	272	39.1	94.6	65	4	4	4	94.8	94.6	93.5
HPC 160	160 M	1800	11	58.0	146	1.45	2.5	272	23.2	93.8	70	3	3	3	93.8	93.2	92.7
	160 M	1800	15	80.0	199	1.45	2.5	272	31.7	94.4	75	4	3	4	94.7	93.9	93.4
	160 M	1800	18.5	98.0	245	1.45	2.5	272	39.1	94.6	75	4	4	4	94.8	94.6	93.5
	160 L	1800	22	117.0	292	1.45	2.5	272	46.5	94.9	85	4	4	4	95.1	94.9	94.9
	160 L	1800	30	159.0	398	1.45	2.5	272	63.4	95.3	100	NA	5	5	NA	95.4	95.2

HPC - COMBINED MOTOR & DRIVE 3000 RPM

EFFICIENCY LEVEL ACCORDING TO IEC 61800-9-2:VFD
DEGREE OF PROTECTION: MOTOR IP55, VFD SIZE 1 TO 4 IP66, VFD SIZE 5 IP55

IES2 IP66

VALUES @ 400 V

Package Type	HPS IE5 MOTOR											IE2 DRIVE			IES2 COMBI		
	Size	Rated Speed	Rated Power	Rated Torque	Peak Torque	Voltage Constant	Torque Constant	Bemf @ rated speed	Rated Current	Efficiency	Weight	Smart	Flow	Plus	Smart	Flow	Plus
		n [rpm]	Pn [kW]	Mn [Nm]	Mpk [Nm]	ke [Vs]	kt [Nm/A]	En [Vrs]	In [Arms]	η [%]	[kg]	Size	Size	Size	η [%]	η [%]	η [%]
HPC 56	56	3000	0.25	0.8	2.4	0.87	1.50	272	0.5	75.8	2.8	1	2	2	74.0	74.7	73.3
	56	3000	0.37	1.2	3.5	0.87	1.50	272	0.8	79.5	3.0	1	2	2	77.7	78.4	76.8
	56	3000	0.55	1.8	5.3	0.87	1.50	272	1.2	82.7	3.2	1	2	2	80.7	81.0	79.9
HPC 71	71	3000	0.75	2.4	7.2	0.87	1.50	272	1.6	84.6	4.8	1	2	2	82.5	82.8	81.6
	71	3000	1.1	3.5	10.5	0.87	1.50	272	2.3	86.2	6.0	2	2	2	85.0	85.5	84.8
	71	3000	1.5	4.8	14.3	0.87	1.50	272	3.2	87.4	6.0	2	2	2	85.7	86.1	85.8
	71	3000	2.2	7.0	21	0.87	1.50	272	4.7	88.9	6.6	2	2	2	87.8	87.7	87.5
HPC 90	90 S-L	3000	2.2	7.0	21	0.87	1.50	272	4.7	88.9	10	2	2	2	87.8	87.7	87.5
	90 S-L	3000	3	9.6	28.7	0.87	1.50	272	6.4	89.9	12	2	2	2	88.8	88.6	88.6
	90 S-L	3000	4	12.7	38.2	0.87	1.50	272	8.5	90.7	14	2	2	2	89.4	89.5	89.9
	90 S-L	3000	5.5	17.5	52.5	0.87	1.50	272	11.7	91.6	16	3	2	3	90.4	90.6	90.5
HPC 112	112 M	3000	5.5	17.5	52.5	0.87	1.50	272	11.7	91.6	23	3	2	3	90.4	90.6	90.5
	112 M	3000	7.5	23.9	71.6	0.87	1.50	272	15.9	92.4	26	3	3	3	91.1	90.9	91.3
	112 M	3000	11	35.0	105.1	0.87	1.50	272	23.3	93.2	30	3	3	3	92.2	91.6	91.9
	112 M	3000	15	47.8	143.3	0.87	1.50	272	31.8	93.7	33	4	3	4	93.3	91.9	92.6
HPC 132	132 M	3000	15	47.8	143.3	0.87	1.50	272	31.8	93.7	55	4	3	4	93.3	91.9	92.6
	132 XL	3000	18.5	58.9	176.7	0.87	1.50	272	39.3	94.2	59	4	4	4	93.7	93.4	92.7
	132 XXL	3000	22	70.0	210.1	0.87	1.50	272	46.7	94.4	67	4	4	4	93.8	93.4	93.4
	132 XXL	3000	30	95.4	286	0.87	1.50	272	63.6	94.9	72	NA	5	5	NA	94.1	93.7
HPC 160	160 L	3000	30	95.4	239	0.87	1.50	272	63.6	94.9	90	NA	5	5	NA	94.1	93.7
	160 L	3000	37	118.0	294	0.87	1.50	272	78.2	95.2	95	NA	5	5	NA	94.3	94.0

HPC - COMBINED MOTOR & DRIVE

3600 RPM

EFFICIENCY LEVEL ACCORDING TO IEC 61800-9-2:VFD
 DEGREE OF PROTECTION: MOTOR IP55, VFD SIZE 1 TO 4 IP66, VFD SIZE 5 IP55

IES2 IP66

VALUES @ 400 V

Package Type	HPS IES MOTOR											IE2 DRIVE			IES2 COMBI		
	Size	Rated Speed	Rated Power	Rated Torque	Peak Torque	Voltage Constant	Torque Constant	Bemf @ rated speed	Rated Current	Efficiency	Weight	Smart	Flow	Plus	Smart	Flow	Plus
		n [rpm]	Pn [kW]	Mn [Nm]	Mpk [Nm]	ke [Vs]	kt [Nm/A]	En [Vrs]	In [Arms]	η [%]	[kg]	Size	Size	Size	η [%]	η [%]	η [%]
HPC 56	56	3600	0.25	0.7	2	0.73	1.26	272	0.5	75.8	2.8	1	2	2	74.2	74.9	73.4
	56	3600	0.37	1.0	2.9	0.73	1.26	272	0.8	79.5	3.0	1	2	2	77.8	78.5	77.0
	56	3600	0.55	1.5	4.4	0.73	1.26	272	1.2	82.7	3.2	1	2	2	80.9	81.2	80.1
HPC 71	71	3600	0.75	2.0	6	0.73	1.26	272	1.6	84.6	4.8	1	2	2	82.7	83.0	81.8
	71	3600	1.1	2.9	8.8	0.73	1.26	272	2.3	86.2	6.0	2	2	2	85.1	85.7	85.0
	71	3600	1.5	4.0	11.9	0.73	1.26	272	3.2	87.4	6.0	2	2	2	85.9	86.2	86.0
	71	3600	2.2	5.8	17.5	0.73	1.26	272	4.6	88.9	6.6	2	2	2	88.0	87.9	87.6
HPC 90	90 S-L	3600	2.2	5.8	17.5	0.73	1.26	272	4.6	88.9	10	2	2	2	88.0	87.9	87.6
	90 S-L	3600	3	8.0	23.9	0.73	1.26	272	6.3	89.9	12	2	2	2	89.0	88.8	88.8
	90 S-L	3600	4	10.6	31.8	0.73	1.26	272	8.4	90.7	14	2	2	2	89.6	89.7	90.0
	90 S-L	3600	5.5	14.6	43.8	0.73	1.26	272	11.6	91.6	16	3	2	3	90.6	90.8	90.7
HPC 112	112 M	3600	5.5	14.6	46.8	0.73	1.26	272	11.6	91.6	23	3	2	3	90.6	90.8	90.7
	112 M	3600	7.5	19.9	59.7	0.73	1.26	272	15.8	92.4	26	3	3	3	91.3	91.1	91.5
	112 M	3600	11	29.2	87.5	0.73	1.26	272	23.2	93.2	30	3	3	3	92.3	91.8	92.1
	112 M	3600	15	39.8	119.4	0.73	1.26	272	31.7	93.7	33	4	3	4	93.5	92.1	92.7
HPC 132	132 M	3600	15	39.8	119.4	0.73	1.26	272	31.7	93.7	55	4	3	4	93.5	92.1	92.7
	132 XL	3600	18.5	49.1	147.2	0.73	1.26	272	39.1	94.2	59	4	4	4	93.9	93.6	92.9
	132 XXL	3600	22	58.4	175.1	0.73	1.26	272	46.5	94.4	67	4	4	4	94.0	93.6	93.6
	132 XXL	3600	30	79.6	238.7	0.73	1.26	272	63.4	94.9	72	NA	5	5	NA	94.3	93.9
HPC 160	160 L	3600	30	79.6	199	0.73	1.26	272	62.9	94.9	85	NA	5	5	NA	94.3	93.9
	160 L	3600	37	98.0	245	0.73	1.26	272	77.6	95.2	90	NA	5	5	NA	94.5	94.2

HPC - COMBINED MOTOR & DRIVE 4500 RPM

EFFICIENCY LEVEL ACCORDING TO IEC 61800-9-2:VFD
DEGREE OF PROTECTION: MOTOR IP55, VFD SIZE 1 TO 4 IP66, VFD SIZE 5 IP55

IES2 IP66

VALUES @ 400 V

Package Type	HPS IE5 MOTOR											IE2 DRIVE			IES2 COMBI		
	Size	Rated Speed	Rated Power	Rated Torque	Peak Torque	Voltage Constant	Torque Constant	Bemf @ rated speed	Rated Current	Efficiency	Weight	Smart	Flow	Plus	Smart	Flow	Plus
		n [rpm]	Pn [kW]	Mn [Nm]	Mpk [Nm]	ke [Vs]	kt [Nm/A]	En [Vrs]	In [Arms]	η [%]	[kg]	Size	Size	Size	η [%]	η [%]	η [%]
HPC 56	56	4500	0.37	0.8	2.4	0.58	1.00	272	0.8	79.5	3.0	1	2	2	74.4	75.1	73.6
	56	4500	0.55	1.2	3.5	0.58	1.00	272	1.2	82.7	3.0	1	2	2	78.0	78.8	77.2
	56	4500	0.75	1.6	4.8	0.58	1.00	272	1.6	84.6	3.2	1	2	2	81.1	81.4	80.3
HPC 71	71	4500	1.1	2.3	7	0.58	1.00	272	2.3	86.2	4.8	1	2	2	83.0	83.2	82.0
	71	4500	1.5	3.2	0.6	0.58	1.00	272	3.2	87.4	5.4	2	2	2	85.4	85.9	85.2
	71	4500	2.2	4.7	14	0.58	1.00	272	4.7	88.9	6.2	2	2	2	86.1	86.5	86.2
	71	4500	3	6.4	19.1	0.58	1.00	272	6.4	89.9	7.2	2	2	2	88.3	88.2	87.9
HPC 90	90 S-L	4500	3	6.4	19.1	0.58	1.00	272	6.4	88.9	12	2	2	2	88.3	88.2	87.9
	90 S-L	4500	4	8.5	25.5	0.58	1.00	272	8.5	90.7	14	2	2	2	89.2	89.1	89.1
	90 S-L	4500	5.5	11.7	35.5	0.58	1.00	272	11.7	91.6	17	2	2	2	89.9	90.0	90.3
	90 S-L	4500	7.5	15.9	47.8	0.58	1.00	272	15.9	92.4	18	3	2	3	90.8	91.0	90.9

HPC - COMBINED MOTOR & DRIVE

1500 RPM

EFFICIENCY LEVEL ACCORDING TO IEC 61800-9-2:VFD
DEGREE OF PROTECTION: MOTOR IP55, VFD SIZE 1 TO 5 IP20

IES2 IP20

VALUES @ 400 V

Package Type	HPS IES MOTOR											IE2 DRIVE			IES2 COMBI		
	Size	Rated Speed	Rated Power	Rated Torque	Peak Torque	Voltage Constant	Torque Constant	Bemf @ rated speed	Rated Current	Efficiency	Weight	Smart	Flow	Plus	Smart	Flow	Plus
		n [rpm]	Pn [kW]	Mn [Nm]	Mpk [Nm]	ke [Vs]	kt [Nm/A]	En [Vrs]	In [Arms]	η [%]	[kg]	Size	Size	Size	η [%]	η [%]	η [%]
HPC 56	56	1500	0.18	1.2	3.4	1.73	3.0	272	0.4	76.3	3	1	2	2	75.0	74.6	74.6
	56	1500	0.25	1.6	4.8	1.73	3.0	272	0.5	79.3	3.2	1	2	2	78.0	77.6	77.6
HPC 71	71	1500	0.55	3.5	9.6	1.73	3.0	272	1.2	85	5.4	1	2	2	83.1	83.1	83.1
	71	1500	0.75	4.8	14	1.73	3.0	272	1.6	86.7	6.2	1	2	2	84.8	84.8	84.8
	71	1500	1.1	7	21	1.73	3.0	272	2.3	88.1	7.2	2	2	2	86.6	86.3	86.4
HPC 90	S-L	1500	1.5	9.6	28.7	1.73	3.0	272	3.2	89.1	14	2	2	2	87.6	87.3	87.4
	S-L	1500	2.2	14	42	1.73	3.0	272	4.7	90.2	14	2	2	2	88.6	88.4	88.6
	XL	1500	3	19.1	57.3	1.73	3.0	272	6.4	91.0	18	2	2	2	89.1	89.2	89.5
	XL	1500	4	25.5	76.4	1.73	3.0	272	8.5	91.8	19	2	2	2	89.9	90.0	90.2
HPC 112	M	1500	4	25.5	76.4	1.73	3.0	272	8.5	91.8	26	2	2	2	89.9	90.0	90.2
	M	1500	5.5	35	105.1	1.73	3.0	272	11.7	92.5	30	3	2	3	90.6	90.7	90.7
	XL	1500	7.5	47.8	143.3	1.73	3.0	272	15.9	93.2	33	3	3	3	91.6	91.1	91.3
	XL	1500	9.2	58.6	175.8	1.73	3.0	272	19.5	93.5	33	3	3	3	91.7	91.5	91.6
HPC 132	XL	1500	11	70	210.1	1.73	3.0	272	23.3	93.8	56	3	3	3	92.0	91.8	91.9
	XXL	1500	15	95.5	286.5	1.73	3.0	272	31.8	94.4	65	4	3	4	92.8	92.7	92.8
	XXL	1500	18.5	117.8	353.4	1.73	3.0	272	39.3	94.6	65	4	4	4	93.0	92.7	92.9
HPC 160	M	1500	11	70	175	1.73	3.0	272	23.3	93.8	70	3	3	3	92.8	92.6	92.7
	M	1500	15	95	239	1.73	3.0	272	31.8	94.4	75	4	3	4	92.8	92.7	92.8
	M	1500	18.5	118	294	1.73	3.0	272	39.3	94.6	85	4	4	4	93.0	92.7	92.9
	L	1500	22	140	350	1.73	3.0	272	46.7	94.9	95	4	4	5	93.1	93.0	93.1
	L	1500	30	191	477	1.73	2.5	272	63.7	95.3	115	5	5	5	93.8	93.5	93.7

HPC - COMBINED MOTOR & DRIVE 1800 RPM

EFFICIENCY LEVEL ACCORDING TO IEC 61800-9-2:VFD
DEGREE OF PROTECTION: MOTOR IP55, VFD SIZE 1 TO 5 IP20

IES2 IP20

VALUES @ 400 V

Package Type	HPS IE5 MOTOR											IE2 DRIVE			IES2 COMBI		
	Size	Rated Speed	Rated Power	Rated Torque	Peak Torque	Voltage Constant	Torque Constant	Bemf @ rated speed	Rated Current	Efficiency	Weight	Smart	Flow	Plus	Smart	Flow	Plus
		n [rpm]	Pn [kW]	Mn [Nm]	Mpk [Nm]	ke [Vs]	kt [Nm/A]	En [Vrs]	In [Arms]	η [%]	[kg]	Size	Size	Size	η [%]	η [%]	η [%]
HPC 56	56	1800	0.18	1	2.9	1.45	2.5	272	0.4	76.3	3	1	2	2	75.0	74.6	74.6
	56	1800	0.25	1.3	4	1.45	2.5	272	0.5	79.3	3.2	1	2	2	78.0	77.6	77.6
HPC 71	71	1800	0.55	2.9	8.8	1.45	2.5	272	1.2	85.0	5	1	2	2	83.1	83.1	83.1
	71	1800	0.75	4	11.9	1.45	2.5	272	1.6	86.7	5.4	1	2	2	84.8	84.8	84.8
	71	1800	1.1	5.8	17.5	1.45	2.5	272	2.3	88.1	7	2	2	2	86.6	86.3	86.4
	71	1800	1.5	8	23.9	1.45	2.5	272	3.2	89.1	7	2	2	2	87.6	87.3	87.4
HPC 90	S-L	1800	1.5	8	23.9	1.45	2.5	272	3.2	89.1	12	2	2	2	87.6	87.3	87.4
	S-L	1800	2.2	11.7	35	1.45	2.5	272	4.6	90.2	14	2	2	2	88.6	88.4	88.6
	S-L	1800	3	15.9	47.7	1.45	2.5	272	6.3	91.0	17	2	2	2	89.1	89.2	89.5
	XL	1800	4	21.2	63.7	1.45	2.5	272	8.4	91.8	18	2	2	2	89.9	90.0	90.2
HPC 112	M	1800	4	21.2	63.7	1.45	2.5	272	8.4	91.8	23	2	2	2	89.9	90.0	90.2
	M	1800	5.5	29.2	87.5	1.45	2.5	272	11.6	92.5	23	3	2	3	90.6	90.7	90.7
	M	1800	7.5	39.8	119.4	1.45	2.5	272	15.8	93.2	30	3	3	3	91.6	91.1	91.3
	XL	1800	11	58.4	175.1	1.45	2.5	272	23.2	93.5	33	3	3	3	91.7	91.5	91.6
HPC 132	M	1800	11	58.4	175.1	1.45	2.5	272	23.2	93.8	54	3	3	3	92.0	91.8	91.9
	XXL	1800	15	79.6	238.7	1.45	2.5	272	31.7	94.4	58	4	3	4	92.8	92.7	92.8
	XXL	1800	18.5	98.1	294.4	1.45	2.5	272	39.1	94.6	65	4	4	4	93.0	92.7	92.9
HPC 160	M	1800	11	58.0	146	1.45	2.5	272	23.2	93.8	70	3	3	3	92.0	91.8	91.9
	M	1800	15	80.0	199	1.45	2.5	272	31.7	94.4	75	4	3	4	92.8	92.7	92.8
	M	1800	18.5	98.0	245	1.45	2.5	272	39.1	94.6	75	4	4	4	93.0	92.7	92.9
	L	1800	22	117.0	292	1.45	2.5	272	46.5	94.9	85	4	4	4	93.1	93.0	93.1
	L	1800	30	159.0	398	1.45	2.5	272	63.4	95.3	100	5	5	5	93.8	93.5	93.7

HPC - COMBINED MOTOR & DRIVE 3000 RPM

EFFICIENCY LEVEL ACCORDING TO IEC 61800-9-2:VFD
DEGREE OF PROTECTION: MOTOR IP55, VFD SIZE 1 TO 5 IP20

IES2 IP20

VALUES @ 400 V

Package Type	HPS IES MOTOR											IE2 DRIVE			IES2 COMBI		
	Size	Rated Speed	Rated Power	Rated Torque	Peak Torque	Voltage Constant	Torque Constant	Bemf @ rated speed	Rated Current	Efficiency	Weight	Smart	Flow	Plus	Smart	Flow	Plus
		n [rpm]	Pn [kW]	Mn [Nm]	Mpk [Nm]	ke [Vs]	kt [Nm/A]	En [Vrs]	In [Arms]	η [%]	[kg]	Size	Size	Size	η [%]	η [%]	η [%]
HPC 56	56	3000	0.25	0.8	2.4	0.87	1.5	272	0.5	75.8	2.8	1	2	2	74.5	74.1	74.1
	56	3000	0.37	1.2	3.5	0.87	1.5	272	0.8	79.5	3	1	2	2	78.1	77.8	77.8
	56	3000	0.55	1.8	5.3	0.87	1.5	272	1.2	82.7	3.2	1	2	2	80.9	80.9	80.9
HPC 71	71	3000	0.75	2.4	7.2	0.87	1.5	272	1.6	84.6	4.8	1	2	2	82.7	82.7	82.7
	71	3000	1.1	3.5	10.5	0.87	1.5	272	2.3	86.2	6	2	2	2	84.7	84.5	84.6
	71	3000	1.5	4.8	14.3	0.87	1.5	272	3.2	87.4	6	2	2	2	85.9	85.7	85.7
	71	3000	2.2	7	21	0.87	1.5	272	4.7	88.9	6.6	2	2	2	87.3	87.1	87.3
HPC 90	S-L	3000	2.2	7	21	0.87	1.5	272	4.7	88.9	10	2	2	2	87.3	87.1	87.3
	S-L	3000	3	9.6	28.7	0.87	1.5	272	6.4	89.9	12	2	2	2	88.0	88.1	88.4
	S-L	3000	4	12.7	38.2	0.87	1.5	272	8.5	90.7	14	2	2	2	88.8	88.9	89.2
	S-L	3000	5.5	17.5	52.5	0.87	1.5	272	11.7	91.6	16	3	2	3	89.7	89.8	89.9
HPC 112	M	3000	5.5	17.5	52.5	0.87	1.5	272	11.7	91.6	23	3	2	3	89.7	89.8	89.9
	M	3000	7.5	23.9	71.6	0.87	1.5	272	15.9	92.4	26	3	3	3	90.8	90.4	90.6
	M	3000	11	35	105.1	0.87	1.5	272	23.3	93.2	30	3	3	3	91.4	91.2	91.3
	M	3000	15	47.8	143.3	0.87	1.5	272	31.8	93.7	33	4	3	4	92.1	92.0	92.1
HPC 132	M	3000	15	47.8	143.3	0.87	1.5	272	31.8	93.7	55	4	3	4	92.1	92.0	92.1
	XL	3000	18.5	58.9	176.7	0.87	1.5	272	39.3	94.2	59	4	4	4	92.6	92.3	92.5
	XXL	3000	22	70	210.1	0.87	1.5	272	46.7	94.4	67	4	4	4	92.6	92.5	92.6
	XXL	3000	30	95.4	286	0.87	1.5	272	63.6	94.9	72	5	5	5	93.4	93.1	93.3
HPC 160	L	3000	30	95.4	239	0.87	1.5	272	63.6	94.9	90	5	5	5	93.4	93.1	93.3
	L	3000	37	118	294	0.87	1.5	272	78.2	95.2	95	5	5	5	93.6	93.2	93.6

HPC - COMBINED MOTOR & DRIVE

3600 RPM

EFFICIENCY LEVEL ACCORDING TO IEC 61800-9-2:VFD
DEGREE OF PROTECTION: MOTOR IP55, VFD SIZE 1 TO 5 IP20

IES2 IP20

VALUES @ 400 V

Package Type	HPS IE5 MOTOR											IE2 DRIVE			IES2 COMBI		
	Size	Rated Speed	Rated Power	Rated Torque	Peak Torque	Voltage Constant	Torque Constant	Bemf @ rated speed	Rated Current	Efficiency	Weight	Smart	Flow	Plus	Smart	Flow	Plus
		n [rpm]	Pn [kW]	Mn [Nm]	Mpk [Nm]	ke [Vs]	kt [Nm/A]	En [Vrs]	In [Arms]	η [%]	[kg]	Size	Size	Size	η [%]	η [%]	η [%]
HPC 56	56	3600	0.25	0.7	2	0.73	1.26	272	0.5	75.8	2.8	1	2	2	74.5	74.1	74.1
	56	3600	0.37	1	2.9	0.73	1.26	272	0.8	79.5	3	1	2	2	78.1	77.8	77.8
	56	3600	0.55	1.5	4.4	0.73	1.26	272	1.2	82.7	3.2	1	2	2	80.9	80.9	80.9
HPC 71	71	3600	0.75	2	6	0.73	1.26	272	1.6	84.6	4.8	1	2	2	82.7	82.7	82.7
	71	3600	1.1	2.9	8.8	0.73	1.26	272	2.3	86.2	6	2	2	2	84.7	84.5	84.6
	71	3600	1.5	4	11.9	0.73	1.26	272	3.2	87.4	6	2	2	2	85.9	85.7	85.7
	71	3600	2.2	5.8	17.5	0.73	1.26	272	4.6	88.9	6.6	2	2	2	87.3	87.1	87.3
HPC 90	S-L	3600	2.2	5.8	17.5	0.73	1.26	272	4.6	88.9	10	2	2	2	87.3	87.1	87.3
	S-L	3600	3	8	23.9	0.73	1.26	272	6.3	89.9	12	2	2	2	88.0	88.1	88.4
	S-L	3600	4	10.6	31.8	0.73	1.26	272	8.4	90.7	14	2	2	2	88.8	88.9	89.2
	S-L	3600	5.5	14.6	43.8	0.73	1.26	272	11.6	91.6	16	3	2	3	89.7	89.8	89.9
HPC 112	M	3600	5.5	14.6	46.8	0.73	1.26	272	11.6	91.6	23	3	2	3	89.7	89.8	89.9
	M	3600	7.5	19.9	59.7	0.73	1.26	272	15.8	92.4	26	3	3	3	90.8	90.4	90.6
	M	3600	11	29.2	87.5	0.73	1.26	272	23.2	93.2	30	3	3	3	91.4	91.2	91.3
	M	3600	15	39.8	119.4	0.73	1.26	272	31.7	93.7	33	4	4	4	92.1	92.0	92.1
HPC 132	M	3600	15	39.8	119.4	0.73	1.26	272	31.7	93.7	55	4	4	4	92.1	92.0	92.1
	XL	3600	18.5	49.1	147.2	0.73	1.26	272	39.1	94.2	59	4	4	4	92.6	92.3	92.5
	XXL	3600	22	58.4	175.1	0.73	1.26	272	46.5	94.4	67	4	4	4	92.6	92.5	92.6
HPC 160	XXL	3600	30	79.6	238.7	0.73	1.26	272	63.4	94.9	72	5	5	5	93.4	93.1	93.3
	L	3600	30	79.6	199	0.73	1.26	272	62.9	94.9	85	5	5	5	93.4	93.1	93.3
	L	3600	37	98	245	0.73	1.26	272	77.6	95.2	90	5	5	5	93.6	93.2	93.6

HPC - COMBINED MOTOR & DRIVE 4500 RPM

EFFICIENCY LEVEL ACCORDING TO IEC 61800-9-2:VFD
DEGREE OF PROTECTION: MOTOR IP55, VFD SIZE 1 TO 5 IP20

IES2 IP20

VALUES @ 400 V

Package Type	HPS IES MOTOR											IE2 DRIVE			IES2 COMBI		
	Size	Rated Speed	Rated Power	Rated Torque	Peak Torque	Voltage Constant	Torque Constant	Bemf @ rated speed	Rated Current	Efficiency	Weight	Smart	Flow	Plus	Smart	Flow	Plus
		n [rpm]	Pn [kW]	Mn [Nm]	Mpk [Nm]	ke [Vs]	kt [Nm/A]	En [Vrs]	In [Arms]	η [%]	[kg]	Size	Size	Size	η [%]	η [%]	η [%]
HPC 56	56	4500	0.37	0.8	2.4	0.58	1.0	272	0.8	79.5	3	1	2	2	78.1	77.8	77.8
	56	4500	0.55	1.2	3.5	0.58	1.0	272	1.2	82.7	3	1	2	2	80.9	80.9	80.9
	56	4500	0.75	1.6	4.8	0.58	1.0	272	1.6	84.6	3.2	1	2	2	82.7	82.7	82.7
HPC 71	71	4500	1.1	2.3	7.0	0.58	1.0	272	2.3	86.2	4.8	1	2	2	84.7	84.5	84.6
	71	4500	1.5	3.2	9.6	0.58	1.0	272	3.2	87.4	5.4	2	2	2	85.9	85.7	85.7
	71	4500	2.2	4.7	14.0	0.58	1.0	272	4.7	88.9	6.2	2	2	2	87.3	87.1	87.3
	71	4500	3	6.4	19.1	0.58	1.0	272	6.4	89.9	7.2	2	2	2	88.0	88.1	88.4
HPC 90	S-L	4500	3	6.4	19.1	0.58	1.0	272	6.4	88.9	12	2	2	2	87.0	87.1	87.4
	S-L	4500	4	8.5	25.5	0.58	1.0	272	8.5	90.7	14	2	2	2	88.8	88.9	89.2
	S-L	4500	5.5	11.7	35.5	0.58	1.0	272	11.7	91.6	17	2	2	2	89.7	89.8	89.9
	S-L	4500	7.5	15.9	47.8	0.58	1.0	272	15.9	92.4	18	3	2	3	90.8	90.4	90.6

DRIVE DIMENSIONS

IP 66 UNIT

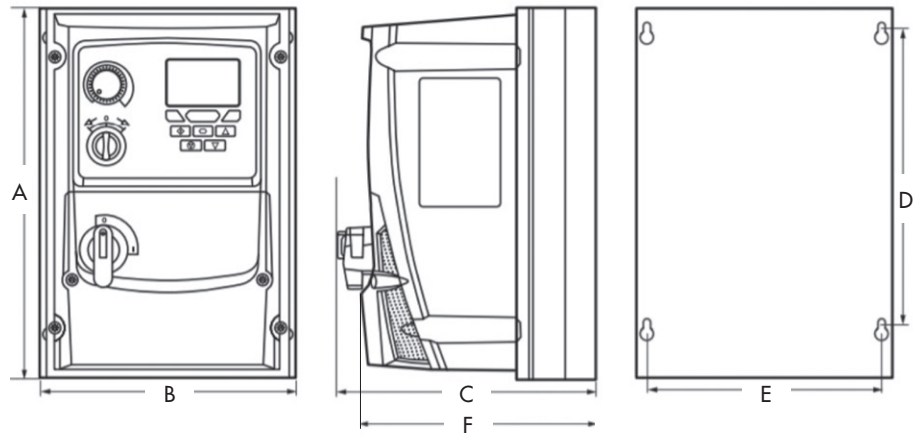

Size	A	B	C	D	E	F*	Bolt	Kg	
								Smart	Flow & Plus
1	232	161	162	189	148.5	NA	M4	2.3	NA
2	257	188	182	200	178	172	M4	3.5	4.8
3	310	211	235	252	197	225	M4	6.6	7.7
4	360	240	271	300	227	260	M4	9.5	9.5

* F: Not switch version

IP 55 UNIT

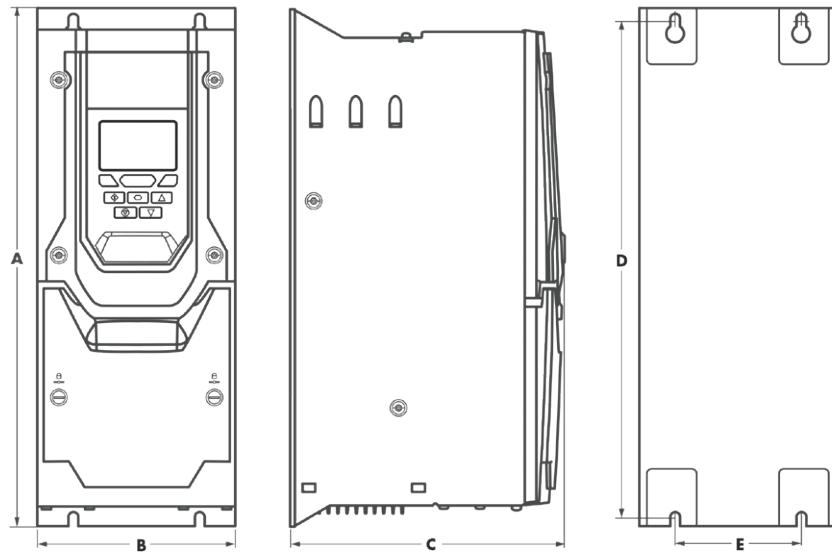

Size	A	B	C	D	E	Bolt	Kg	
							Smart	Flow & Plus
5	540	235	270	520	175	M8	NA	23

DRIVE DIMENSIONS

IP 20 UNIT

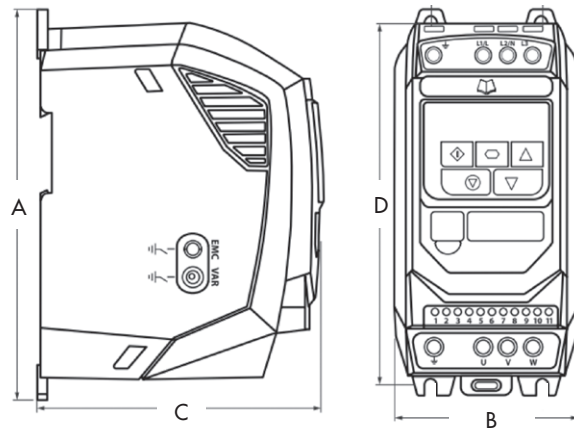

Size	A	B	C	D	E	Bolt	Kg	
							Smart	Flow & Plus
1	173	83	123	162	50	4xM5	1.0	NA
2	221	110	150	209	63	4xM5	1.7	1.8
3	261	131	175	247	80	4xM5	3.2	3.5
4	420	171	212	400	125	4xM8	9.1	10.4
5	486	222	226	463	175	4xM8	18.1	19.9

HP Integral

Smart  Flow  Plus 
solutions to meet your needs



RANGE OVERVIEW

HP Integral is an innovative **motor-drive integration** that combines a **PM (permanent magnet) synchronous motor with a VFD (Variable Frequency Drive)**, achieving very **High Efficiency** levels.

The motor range leverages both brushless servo motor and AC induction motor technologies, so enhancing the power density and allowing for significant **size and weight reductions up to 50%**.

The drive is fully integrated with the motor into a dedicated case, so granting a very compact design and further reducing overall dimensions and weight.

Several drive configurations are available to cover a wide range of industrial and commercial applications: **variable torque applications**, typically in HVAC, as well as **constant torque applications** like material handling, air compressors and vacuum pumps.

PRODUCT LINE	FEATURES	FRAME SIZE	TORQUE		MAIN APPLICATIONS
			CONSTANT	VARIABLE	
HP Integral	<ul style="list-style-type: none"> Available also in single-phase supply voltage Easy-to-use built-in keypad as option 	71		✓	<ul style="list-style-type: none"> HVAC
HP Integral Smart	<ul style="list-style-type: none"> Smart configuration Suitable for most applications Industrial, Pump & Fan modes 	90-112	✓	✓	<ul style="list-style-type: none"> General Industrial HVAC
HP Integral Flow	<ul style="list-style-type: none"> Dedicated control functions for HVAC Innovative energy saving features Built-in PLC capability 	90-112		✓	<ul style="list-style-type: none"> Advanced HVAC
HP Integral Plus	<ul style="list-style-type: none"> Advanced configuration Maximum performance, motor control Built-in PLC capability Flexible functionality 	90-112	✓	✓	<ul style="list-style-type: none"> Demanding Industrial Compressors Vacuum pumps Material handling

HEIGHT COMPARISON | HPI 90 VS AC 112

AC MOTOR	HPI MOTOR
SIZE 90 - 2.2 kW 16 KG	SIZE 71 - 2.2 kW 9.1 KG
SIZE 112 - 5.5 KW 34 KG	SIZE 90 - 5.5 KW 19.5 KG
SIZE 132 - 7.5 KW 53 KG	SIZE 112 - 7.5 KW 31.5 KG

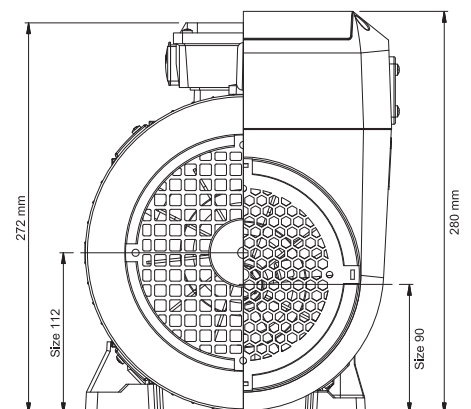

VARIABLE FREQUENCY DRIVE (VFD) - SPECIFICATIONS

HP Integral

HP Integral Smart

HP Integral Flow

HP Integral Plus

MAIN SUPPLY

Supply Frequency	48-62 Hz	48-62 Hz	48-62Hz	48-62Hz
Single-phase	200-240 V ± 10%	NA	NA	NA
Three-phase	200-230 V ± 10%	200-240 V ± 10%	200-240 V ± 10%	200-240 V ± 10%
	380-480 V ± 10%	380-480 V ± 10%	380-480 V ± 10%	380-480 V ± 10%
			500-600 V ± 10%	500-600 V ± 10%

OUTPUT RATINGS

Power Ratings	Up to 2.2 kW	Up to 11 kW	Up to 15 kW	Up to 11 kW
Overload Capacity	150% for 60 seconds	150% for 60 seconds 175% for 2.5 seconds	110% for 60 seconds 165% for 4 seconds	150% for 60 seconds 200% for 4 seconds

PROGRAMMABLE INPUTS

2 Analog	2 Digital	3 Digital (+3 optional)	3 Digital (+3 optional)
2 Digital	2 Analog / Digital selectable	2 Analog / Digital selectable	2 Analog / Digital selectable

PROGRAMMABLE OUTPUTS

2 Analog	1 Analog / Digital	2 Analog / Digital	2 Analog / Digital
2 Digital	1 Relay	2 Relays (+3 optional)	2 Relays (+3 optional)
2 Relays			

BUILT IN FIELDBUS

Modbus RTU	CANopen	BACnet MS/TP	CANopen
	Modbus RTU	Modbus RTU	Modbus RTU
Other options available	Other options available	Other options available	Other options available

INTERNAL EMC FILTER

✓	✓	✓*	✓*
---	---	----	----

INTERNAL BRAKE TRANSISTOR

NA	✓**	NA	✓
----	-----	----	---

ENCLOSURE

Non-switched	Switched or non-switched	With or without disconnecter	Switched or non-switched
--------------	--------------------------	------------------------------	--------------------------

PI(D) CONTROL

Internal PI controller	Internal PI controller Standby / sleep function	Internal PID controller STO function Programmable PLC Multi setpoint select Standby / sleep function	Internal PID controller STO function Programmable PLC Multi setpoint select Standby / sleep function
-------------------------------	---	---	---

* Not available for 500-600V drives ** Not available in size 1

SAFE TORQUE OFF (PROVIDED AS STANDARD)

HPI Flow and Plus feature a safe torque off function to allow simple integration into machine critical safety circuits.









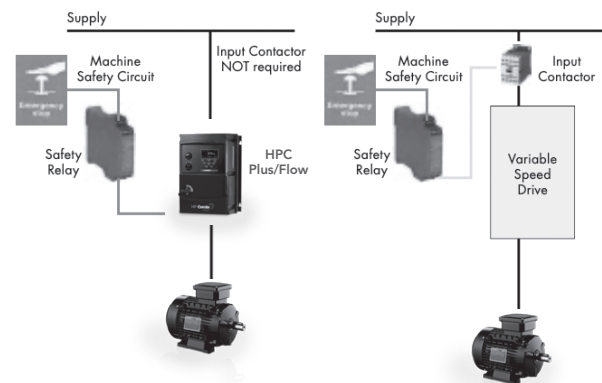

- Simple machine design reduces component costs, saves panel space and minimises installation time
- Faster shut down and reset procedures reduce system maintenance time
- Better safety standard compared to mechanical solution
- Better motor connection. Single cable with no interruption.



WITH

WITHOUT



TYPE	DESCRIPTION	Smart 	Flow 	Plus+ 
COMMUNICATION INTERFACES	 EtherCAT Plug in Interface Module		✓	✓
	 Profibus DPV-1 Plug in Interface Module		✓	✓
	 Profibus External Gateway & Cables	✓	✓	✓
	 Profinet IO Plug in Interface Module		✓	✓
	 EthernetIP Plug in Interface Module EtherNet Module	✓	✓	✓
	 DeviceNet Plug in Interface Module DeviceNET External Gateway & Cables	✓	✓	✓
	 Bacnet IP Plug in Interface		✓	
	 Modbus TCP Plug in Interface Module		✓	✓
COMMUNICATION OPTIONS	HP Drive Stick with Bluetooth Interface	✓	✓	✓
	USB PC Connection Kit	✓	✓	✓
I/O OPTIONS	Cascade Control Plug in Option Module		✓	✓
	Extended I/O Plug in Option Module		✓	✓
PLC LICENCE	HP Drive Tools PLC Function Single PC Licence			✓

HP Drive TOOLS



HP DRIVE TOOLS FOR PC

- Plain language descriptions with range and units
- Notes and advice concerning related parameters
- Parameter upload/download from VFD & electronic storage
- Print parameter set with changed parameters highlighted
- Multi-drive network support with one convenient connection
- Ghost parameters for ease of use or security
- Lock drive parameters to prevent user tampering
- Powerful scope function for commissioning and analysis
- Optional function block PLC
- PLC program protection to prevent unauthorized copying
- Connection via USB to RJ45 or HP Drive Stick



HP DRIVE TOOLS FOR MOBILE

- Mobile app available for iOS and Android
- Wireless drive commissioning using
- HP Drive stick
- Parameter file creation, upload, download & Storage
- Changed parameter highlighting
- Offline parameter file management
- Mobile to mobile parameter file sharing

* HP Drive Tools is not available for HPI size 71

HPI - MOTOR WITH INTEGRATED DRIVE 1500, 1800 RPM

EFFICIENCY LEVEL ACCORDING TO IEC 61800-9-2:VFD
DEGREE OF PROTECTION: MOTOR IP55, VFD IP66

IES2

VALUES @ 400 V

Type	Rated Speed n [rpm]	Rated Power Pn [kW]	Rated Torque Mn [Nm]	Peak Torque Mpk [Nm]	Motor Rated Current In [Arms]	Motor Peak Current Ipk [Arms]	Rated input current		Torque Constant Kt [Nm/A]	Weight HPI [kg]	Efficiency HPI			
							380Vac	480Vac			Integral	Smart	Flow	Plus
							lin [Arms]	lin [Arms]			η [%]	η [%]	η [%]	η [%]
1500 rpm														
HPI71 1500 12	1500	0.55	3.5	5.3	1.2	1.8	1.3	1.0	3.0	7.3	81.1	-	-	-
HPI71 1500 16	1500	0.75	4.8	7.2	1.6	2.4	1.7	1.4	3.0	7.9	81.8	-	-	-
HPI71 1500 23	1500	1.1	7.0	10.5	2.3	3.5	2.5	2.0	3.0	8.7	83.0	-	-	-
HPI71 1500 32	1500	1.5	9.6	14.4	3.2	4.8	3.4	2.7	3.0	9.5	83.6	-	-	-
HPI90 1500 32	1500	1.5	9.6	14.4	3.2	4.8	3.4	2.7	3.0	13.5	-	88.3	88.5	87.6
HPI90 1500 47	1500	2.2	14.0	21.0	4.7	7.0	4.9	3.9	3.0	15.5	-	89.7	89.4	88.7
HPI90 1500 64	1500	3	19.1	28.7	6.4	9.6	6.6	5.2	3.0	17.5	-	90.4	90.1	90.2
HPI90 1500 85	1500	4	25.5	38.3	8.5	12.7	8.8	7.0	3.0	20.5	-	91.3	90.8	90.7
HPI112 1500 85	1500	4	25.5	38.3	8.5	12.7	8.7	6.9	3.0	28.5	-	91.2	90.8	90.7
HPI112 1500 117	1500	5.5	35.0	52.5	11.7	17.5	11.9	9.4	3.0	31.5	-	92.0	92.2	91.5
HPI112 1500 159	1500	7.5	47.8	71.7	15.9	23.9	16.2	12.8	3.0	35.5	-	92.7	92.8	92.0
1800 rpm														
HPI71 1800 12	1800	0.55	2.9	4.4	1.2	1.7	1.3	1.0	2.5	7.3	83.3	-	-	-
HPI71 1800 16	1800	0.75	4.0	6.0	1.6	2.4	1.7	1.4	2.5	7.9	84.9	-	-	-
HPI71 1800 23	1800	1.1	5.8	8.8	2.3	3.5	2.5	2.0	2.5	8.7	85.3	-	-	-
HPI71 1800 32	1800	1.5	8.0	11.9	3.2	4.8	3.4	2.7	2.5	9.5	85.8	-	-	-
HPI90 1800 32	1800	1.5	8.0	11.9	3.2	4.8	3.4	2.7	2.5	13.5	-	88.7	88.9	88.0
HPI90 1800 46	1800	2.2	11.7	17.5	4.6	7.0	4.9	3.9	2.5	15.5	-	89.9	89.6	89.0
HPI90 1800 63	1800	3	15.9	23.9	6.3	9.5	6.6	5.2	2.5	17.5	-	90.6	90.3	90.4
HPI90 1800 84	1800	4	21.2	31.8	8.4	12.7	8.8	7.0	2.5	20.5	-	91.4	90.9	90.8
HPI112 1800 84	1800	4	21.2	31.8	8.4	12.7	8.7	6.9	2.5	28.5	-	91.4	90.9	90.8
HPI112 1800 116	1800	5.5	29.2	43.8	11.6	17.4	11.9	9.4	2.5	31.5	-	92.1	92.4	91.6
HPI112 1800 158	1800	7.5	39.8	59.7	15.8	23.8	16.2	12.8	2.5	35.5	-	92.9	92.9	92.2
HPI112 1800 232	1800	11	58.4	87.5	23.2	34.9	23.6	18.7	2.5	38.5	-	93.5	92.9	92.5

HPI - MOTOR WITH INTEGRATED DRIVE 3000, 3600, 4500 RPM

EFFICIENCY LEVEL ACCORDING TO IEC 61800-9-2:VFD
DEGREE OF PROTECTION: MOTOR IP55, VFD IP66

IES2

VALUES @ 400 V

Type	Rated Speed	Rated Power	Rated Torque	Peak Torque	Motor Rated Current	Motor Peak Current	Rated input current		Torque Constant	Weight HPI	Efficiency HPI			
							380Vac	480Vac			Integral	Smart	Flow	Plus
							lin [Arms]	lin [Arms]						
3000 rpm														
HPI71 3000 16	3000	0.75	2.4	3.6	1.6	2.4	1.7	1.3	1.5	7.3	85.5	-	-	-
HPI71 3000 23	3000	1.1	3.5	5.3	2.3	3.5	2.4	1.9	1.5	7.9	86.9	-	-	-
HPI71 3000 32	3000	1.5	4.8	7.2	3.2	4.8	3.3	2.6	1.5	8.5	87.4	-	-	-
HPI71 3000 47	3000	2.2	7.0	10.5	4.7	7.0	4.8	3.8	1.5	9.1	87.7	-	-	-
HPI90 3000 47	3000	2.2	7.0	10.5	4.7	7.0	4.8	3.8	1.5	13.5	-	88.7	88.9	88.0
HPI90 3000 64	3000	3	9.6	14.4	6.4	9.6	6.4	5.1	1.5	15.5	-	89.9	89.6	89.0
HPI90 3000 85	3000	4	12.7	19.1	8.5	12.7	8.5	6.8	1.5	17.5	-	90.6	90.3	90.4
HPI90 3000 117	3000	5.5	17.5	26.3	11.7	17.5	11.7	9.3	1.5	19.5	-	91.4	90.9	90.8
HPI112 3000 117	3000	5.5	17.5	26.3	11.7	17.5	11.9	9.4	1.5	28.5	-	91.4	90.9	90.8
HPI112 3000 159	3000	7.5	23.9	35.9	15.9	23.9	15.9	12.5	1.5	31.5	-	92.1	92.4	91.6
HPI112 3000 233	3000	11	35.0	52.5	23.3	35.0	23.2	18.4	1.5	35.5	-	92.9	92.9	92.2
HPI112 3000 318	3000	15	47.8	71.7	31.8	47.8	31.5	25.0	1.5	38.5	-	NA	92.9	NA
3600 rpm														
HPI71 3600 16	3600	0.75	2.0	3.0	1.6	2.4	1.7	1.3	1.26	7.3	86.4	-	-	-
HPI71 3600 23	3600	1.1	2.9	4.4	2.3	3.5	2.4	1.9	1.26	7.9	87.2	-	-	-
HPI71 3600 32	3600	1.5	4.0	6.0	3.2	4.8	3.3	2.6	1.26	8.5	87.9	-	-	-
HPI71 3600 46	3600	2.2	5.8	8.8	4.6	7.0	4.8	3.8	1.26	9.1	88.1	-	-	-
HPI90 3600 46	3600	2.2	5.8	8.8	4.6	7.0	4.8	3.8	1.26	13.5	-	88.0	87.9	87.6
HPI90 3600 63	3600	3	8.0	11.9	6.3	9.5	6.4	5.1	1.26	15.5	-	89.0	88.8	88.8
HPI90 3600 84	3600	4	10.6	15.9	8.4	12.7	8.5	6.8	1.26	17.5	-	89.6	89.7	90.0
HPI90 3600 116	3600	5.5	14.6	21.9	11.6	17.4	11.7	9.3	1.26	19.5	-	90.6	90.8	90.7
HPI112 3600 116	3600	5.5	14.6	21.9	11.6	17.4	11.9	9.4	1.26	28.5	-	93.5	92.1	92.7
HPI112 3600 158	3600	7.5	19.9	29.8	15.8	23.8	15.9	12.5	1.26	31.5	-	93.9	93.6	92.9
HPI112 3600 232	3600	11	29.2	43.8	23.2	34.9	23.2	18.4	1.26	35.5	-	94.0	93.6	93.6
HPI112 3600 317	3600	15	39.8	59.7	31.7	47.5	31.5	25.0	1.26	38.5	-	NA	94.5	NA
4500 rpm														
HPI71 4500 23	4500	1.1	2.3	7.0	2.3	3.5	2.4	1.9	1.0	7.3	86.4	-	-	-
HPI71 4500 32	4500	1.5	3.2	3.5	3.2	4.8	3.3	2.6	1.0	7.9	87.3	-	-	-
HPI71 4500 47	4500	2.2	4.7	6.8	4.7	7.0	4.8	3.8	1.0	8.7	88.1	-	-	-
HPI71 4500 64	4500	3	6.4	7.1	6.4	9.6	6.5	5.1	1.0	9.5	88.2	-	-	-
HPI90 4500 64	4500	3	6.4	9.6	6.4	9.6	6.4	5.1	1.0	13.5	-	88.7	88.9	88.0
HPI90 4500 85	4500	4	8.5	9.6	8.5	12.7	8.5	6.8	1.0	15.5	-	89.9	89.6	89.0
HPI90 4500 117	4500	5.5	11.7	12.7	11.7	17.5	11.7	9.3	1.0	17.5	-	90.6	90.3	90.4
HPI90 4500 159	4500	7.5	15.9	17.5	15.9	23.9	15.9	12.6	1.0	20.5	-	91.4	90.9	90.8

DIMENSIONS FRAME SIZE 71 - 90 - 112 IM B3 ALUMINIUM ALLOY FRAME

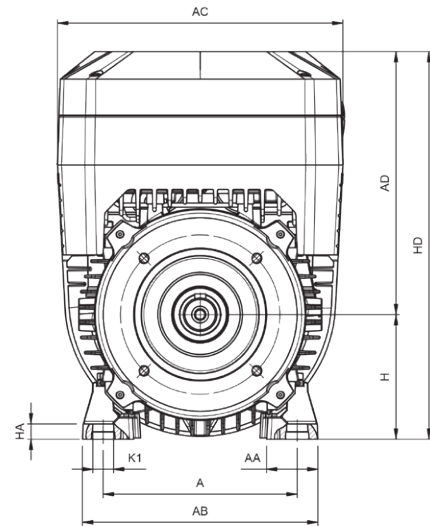
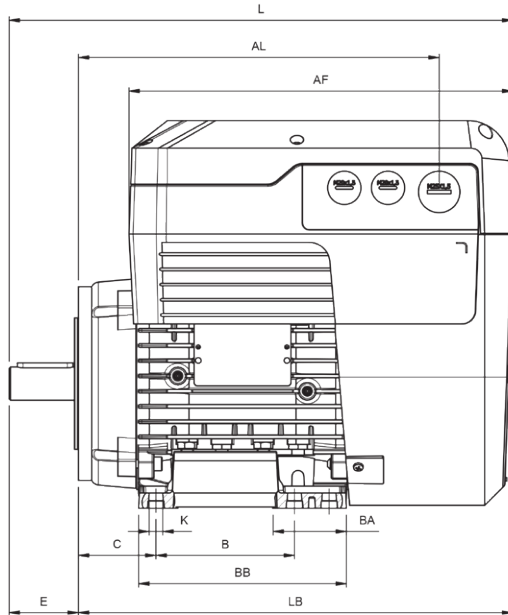

IEC	H	A	B	C	K ¹⁾	AB	BB	AD ²⁾	HD ²⁾	AC	HA
71	71	112	90	45	8	135	108	160	231	174	8.5
90 Smart	90	140	100	56	10	170	150	190	280	206	11
90 Flow - Plus	90	140	125	56	10	170	150	213	303	206	11
112 Smart	112	190	140	70	12.5	220	176	226	338	241	15
112 Flow - Plus	112	190	140	70	12.5	220	176	251	363	241	15

IEC	K1	L	LB	AL	AF	BA	AA	D	E	F	GD	GA	DB ³⁾
71	11	275	235	182	211	28	31	19	40	6	6	22	M6
90 Smart - Flow - Plus	15	363	277	260	313	28/53	37	24	50	8	7	27	M8
112 Smart - Flow - Plus	19	439	332	326	379	46	48	28	60	8	7	31	M10

1) Clearance hole for screw

2) Maximum distance

3) Centering holes in shaft extensions to DIN 332 part 2



The internal pages of this catalogue are made with Freelife Cento by Fedrigoni, the eco-friendly 100% recycled paper produced with recovered waste and low CO₂ emissions.

All technical data, outputs, dimensions and weights stated in this catalogue are subject to change without prior notice. The illustrations are not binding.

Printed in October 2024.

PRODUCT RANGE OVERVIEW

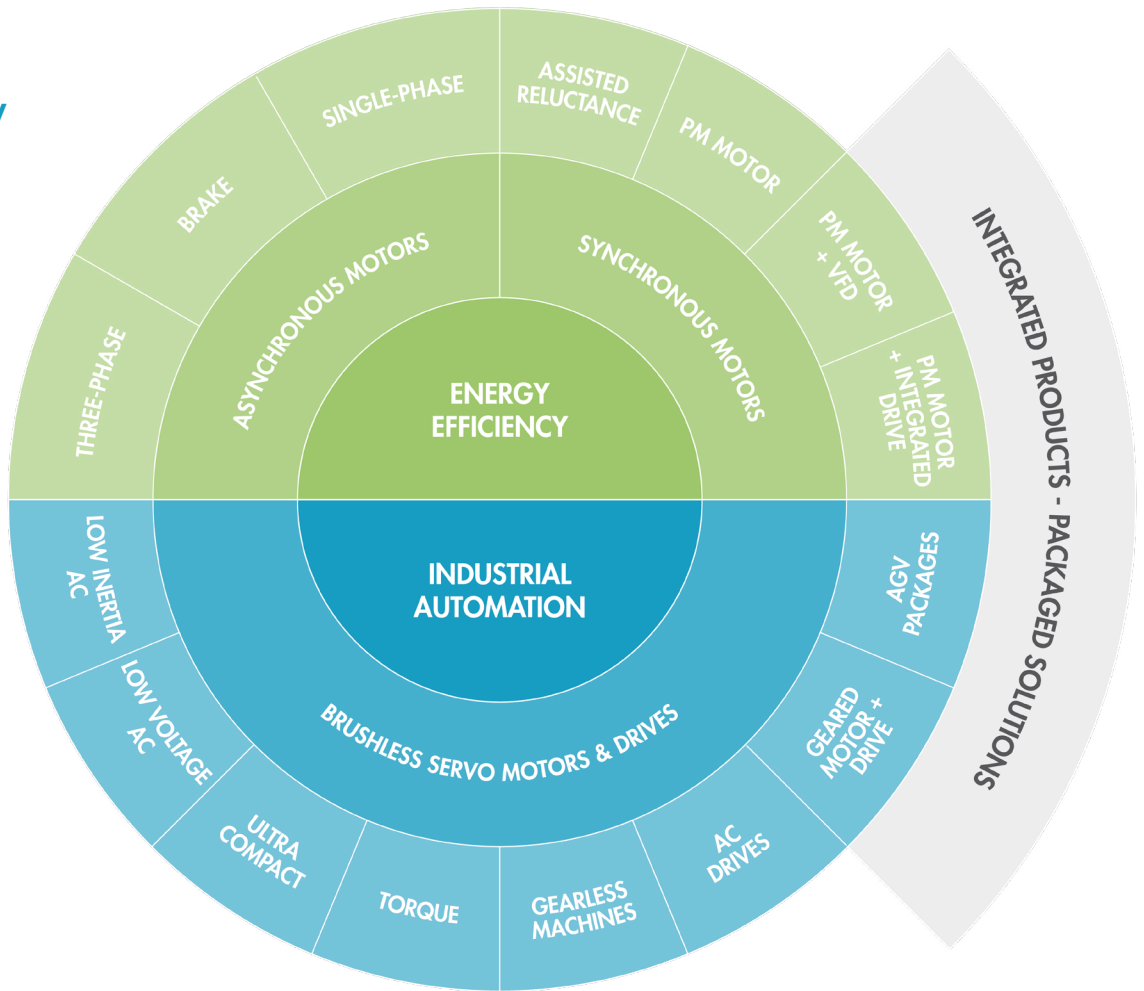

THREE-PHASE MOTORS
FIRST IN ENERGY SAVING

IE3 IE4 ENERGY C **us**



PM MOTOR & DRIVE PACKAGES

IE4 IE5 C **us**



PM MOTORS WITH INTEGRATED DRIVE

IES2 C **us**

APPLICATION RANGE OVERVIEW

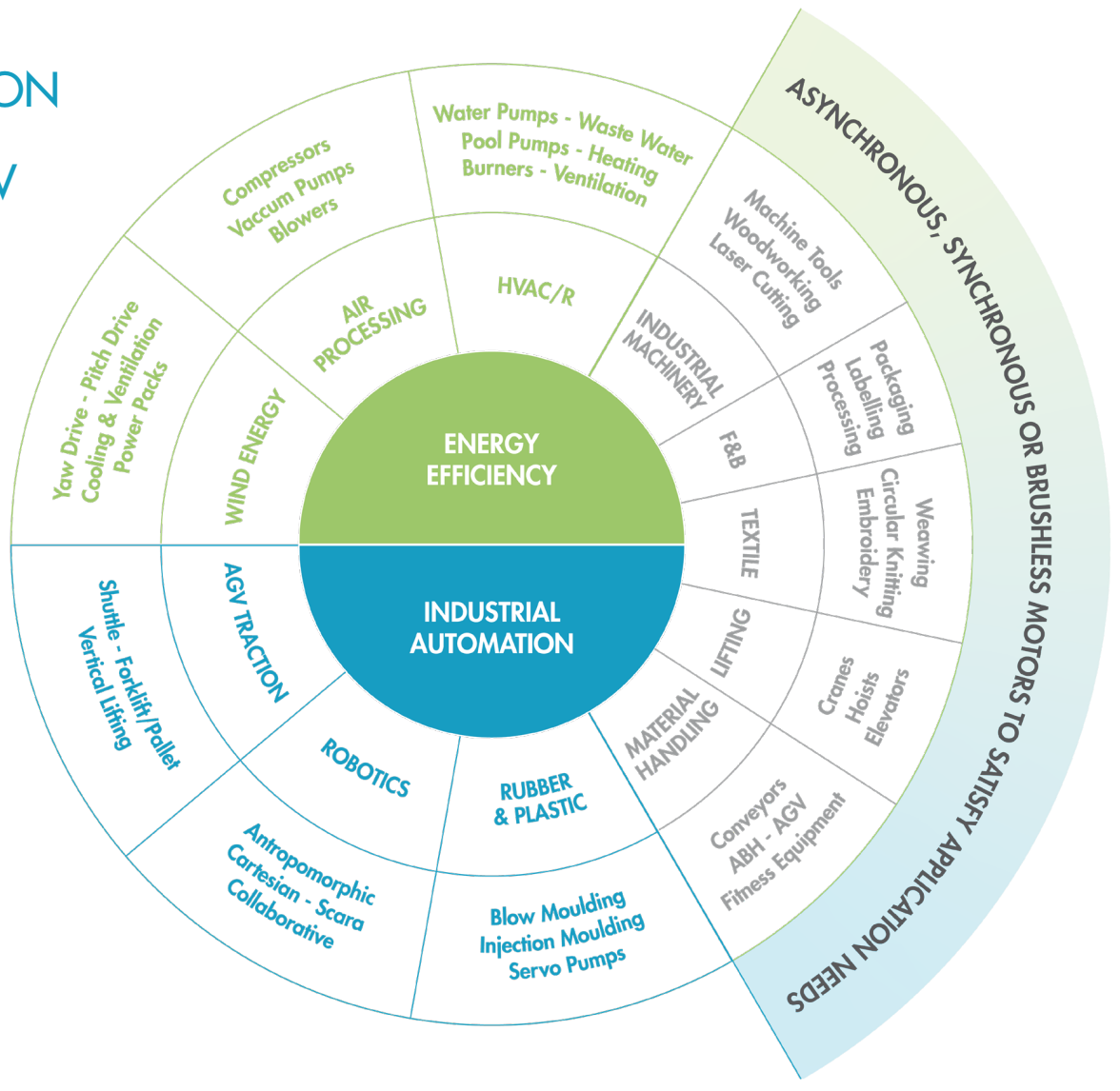

DIRECT DRIVE MOTORS WITH INTEGRATED DRIVE



SERVO MOTORS & DRIVES
TOP PERFORMANCE,
REDUCED DIMENSIONS

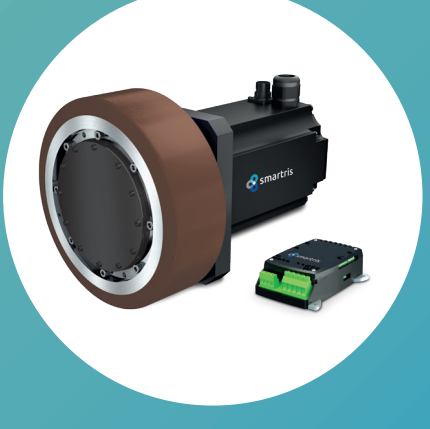

SMARTRIS
PACKAGED-DRIVE SYSTEM
SOLUTIONS FOR AGV





Branches & Partners

Lafert GmbH

Wolf-Hirth-Straße 10
71034 Böblingen
Germany
Phone +49 175 550 4526
lge.info@shi-g.com

Lafert Electric Motors Ltd.

Unit 17 Orion Way
Crewe, Cheshire CW1 6NG
United Kingdom
Phone +44 / (0) 1270 270 022
luk.info@shi-g.com

Lafert Moteurs S.A.S.

L'Isle d'Abeau Parc de Chesnes
75, rue de Malacombe
38070 St. Quentin-Fallavier
France
Phone +33 / 474 95 41 01
lfr.info@shi-g.com

Lafert Motores Electricos, S.L.U.

Poligono Pignatelli, Nave 27
50410 Cuarte de Huerva (Zaragoza)
Spain
Phone +34 / 976 503 822
les.info@shi-g.com

Lafert N.A. (North America)

5620 Kennedy Road - Mississauga
Ontario L4Z 2A9
Canada
Phone +1 / 800/661 6413 - 905/629 1939
lna.info@shi-g.com

Lafert Electric Motors (Australia)

Factory 3, 117-123 Abbott Road,
Hallam - VIC 3803
Australia
Phone +61 / (0)3 95 46 75 15
info@lafertaust.com.au

Lafert Singapore Pte Ltd

48 Hillview Terrace #06-06
Hillview Building - Singapore 669269
Phone +65 / 67630400 - 67620400
info@lafert.com.sg

Lafert (Suzhou) Co., Ltd.

No.3 Industrial Plant Building Yue Xi Phase 3,
Tian E Dang Lu 2011, 215104 Wuzong
Economic Development Zone, Suzhou
China
Phone +86 / 512 6687 0618
lsu.info@shi-g.com

Lafert S.p.A.

J. F. Kennedy, 43
30027 San Donà di Piave (Venezia), Italy
Tel. +39 / 0421 229 611
lafert.info@shi-g.com

www.lafert.com

