

IFM RANGE

HVLS APPLICATIONS

INTEGRATED DIRECT DRIVE FAN MOTORS



IFM SYSTEM

Ventilation systems can be designed in many different ways to produce an effective and efficient system. For use in those buildings that have spacious halls or rooms, a new economical way is available to secure an even temperature distribution and correct cooling. A new concept is to use **low speed Permanent Magnet Synchronous Motors** running fans with big diameters (up to 7 m) and reduce energy consumption.

The innovative low speed Permanent Magnet Synchronous Motors, specifically designed for HVLS (High Volume Low Speed) fans with big diameters are offered under the name **Integrated Direct Drive Fan Motor - IFM**. The fan speed can be controlled by the built-in drive and because the system is completely gearless, efficiency is increased and maintenance significantly reduced.

GO BIG - REALIZE BIG SAVINGS

Low speed IFM offer the advantage of moving a significant amount of air whilst consuming less energy compared to traditional ventilation systems. In many cases **more than 50% energy saving** is expected. Low speed IFM also offer the advantage of very **low noise levels** and improve the environment, making conditions cooler and more comfortable.



TARGET APPLICATIONS

Buildings and constructions with need for cooling and mixing of air to improve the **environment for humans and animals**.

- Shopping centers
- Hotel lobby
- Reception areas
- Sport centers
- Industrial production facilities
- Stables

MAIN FEATURES

- Rated torque up to 170 Nm
- 400 Vac three-phase, 230 Vac single-phase
- Motor control at low speed down to 1-2 rpm
- Compliance to Electromagnetic Compatibility Directive - EMC 2014/30/EC
- **ETL Certification**

ADVANTAGES

Permanent Magnet rotor design achieving the highest efficiency values

Distribute the temperature and zone control

Secure the optimisation of the air condition system

Since IFM are variable speed, the air flow speed can be controlled according to the temperature condition

In case of power supply's failure the drive has the ability to catch the rotating fan (wind milling) in order to prevent eventual system alarms

No gearbox to maintain due to direct driven fan



The IFM solution is a dedicated range of products intended to be integrated directly into a machine. All units consist of a power module (PM) and a control module (CM), which, combined together, become a complete drive unit. This construction method provides greater flexibility. In addition, an optional fieldbus interface can be added, allowing direct and enhanced way of motor control.



PERFORMANCE DATA

Type		IFM 10	IFM 20	IFM 30	IFM 40
Rated speed	n [rpm]	Up to 160	Up to 120	Up to 75	Up to 75
Rated power	Pn [W]	637	875	785	1335
Rated torque	Mn [Nm]	Up to 40	Up to 80	Up to 120	Up to 170
Voltage constant	Ke [Vs]	10.2	22	31.7	37.3
Torque constant	Kt [Nm/A]	17.7	38.1	54.9	64.6
Resistance phase to phase	Rw [Ω]	16.8	26.3	39.4	39.9
Inductance phase to phase	Lw [mH]	135	255	380	510
BEMF at rated speed	En [Vrms]	171	253	249	293
Rated current at Max Speed	In [Arms]	2.3	2	2.2	2.6
Enclosure temperature rise	[K]	16	17	18	20
System Efficiency*	[%]	IES2	IES2	IES2	IES2
Motor Efficiency	[%]	IE5	IE5	IE5	IE5

* System = motor + drive

THE RANGE

- **TYPE IFM 10:** up to 40 Nm
- **TYPE IFM 20:** up to 80 Nm
- **TYPE IFM 30:** up to 110 Nm
- **TYPE IFM 40:** up to 170 Nm

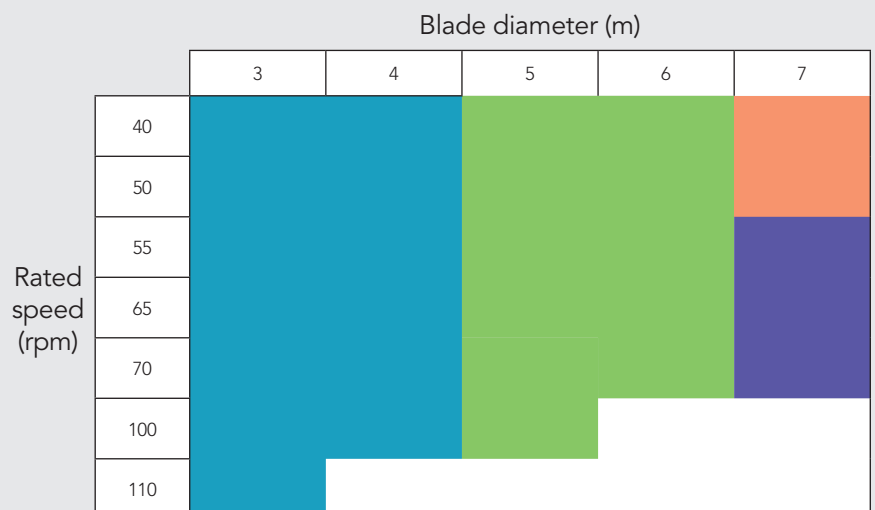

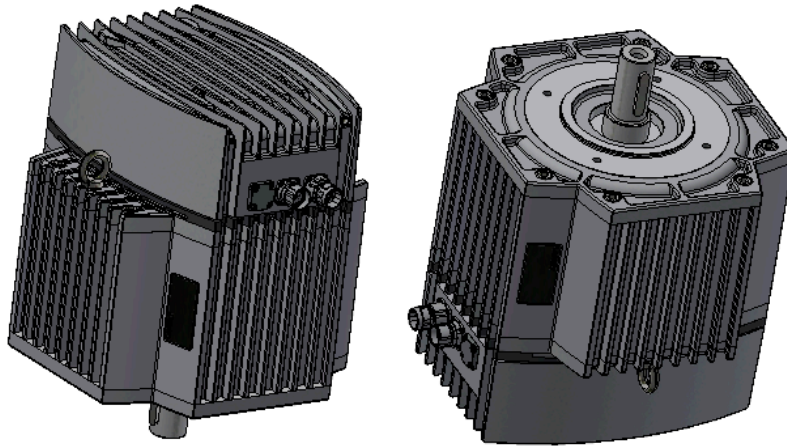
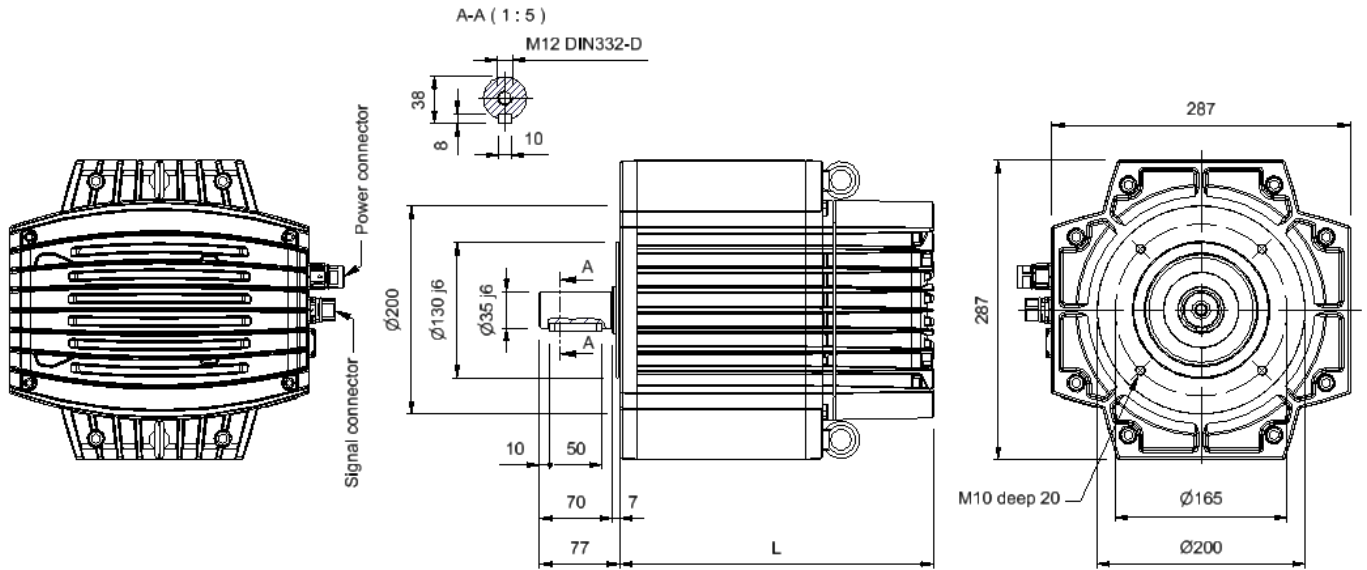

MOTOR SPECIFICATIONS

Mounting	IMB14
IP Protection	IP55
Bearing lifetime	>20.000h
Corrosion Protection	C3-H
Duty	S1
Insulation Class (ΔT)	F(B)
Type of Cooling	AOM
Ambient Temperature [°C]	-10...+50 ⁽¹⁾

⁽¹⁾ from 40 to 50 with derating on the rated torque

TYPE	IFM10	IFM20	IFM30	IFM40
Length [L]	260 mm	302 mm	324 mm	364 mm
Weight	27.5 kg	33.8 kg	45.3 kg	56 kg
Bearing DE	6309 2RS	6309 2RS	6310 2RS	6310 2RS
Bearing NDE	6309 2RS	6309 2RS	6309 2RS	6309 2RS

DRIVE SPECIFICATIONS

Power Supply	380 ÷ 480V ± 10 %, 3 ϕ 200 ÷ 240V ± 10 %, 1 ϕ
Control	Sensorless PM
Line Filter	EMC Filter, Harmonic filter (both built in) Active PFC built in for Single Phase release
Speed / Position Control	External Analogic Signal 0-10 Vdc External Pot Serial (Protocol MOD-BUS, CAN)
Drive IP Rating	IP67
Drive Mounting	Integrated in the NDE side UL Certified

SIGNAL CONNECTOR

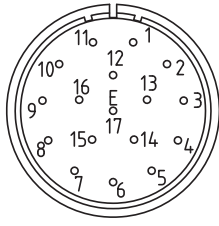

Pin	Signal	Color
1	+24V User Output	White
2	Digital Input 1	Brown
3	Digital Input 2	Green
4	Digital Input 3/An.In2	Yellow
5	+10V User Output	Grey
6	Analog Input1/Dig In.4	Pink
7	0V	Blue
8	Ana/Dig Output	Red
9	0V	Black
10	ModBus RTU-	Violet
11	ModBus RTU+	Grey/Pink
12	RL1-A – Status Relay	Red/Blue
13	RL1-B – Status Relay	White/Green
14	n.c.	-
15	n.c.	-
16	n.c.	-
17	n.c.	-

POWER CONNECTOR

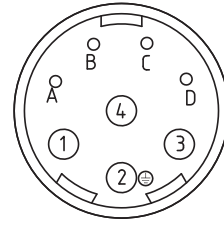

Pin	Signal	Description
1	L1	Fase L1
2	L2	Fase L2
3	L3	n.c.
PE	Ground	Motor Case
A	n.c.	n.c.
B	n.c.	n.c.
C	n.c.	n.c.
D	n.c.	n.c.



Lafert S.p.A.

Via J.F. Kennedy,43
30027 San Donà di Piave (Venice), Italy
Tel. +39 / 0421 229 611
lafert.info@shi-g.com

www.lafert.com

Branches & Partners**Lafert GmbH**

Wolf-Hirth-Straße 10
71034 Böblingen
Germany
Phone +49 175 550 4526
lge.info@shi-g.com

Lafert Electric Motors Ltd.

Unit 17 Orion Way
Crewe, Cheshire CW1 6NG
United Kingdom
Phone +44 / (0) 1270 270 022
luk.info@shi-g.com

Lafert Moteurs S.A.S.

L'Isle d'Abeau Parc de Chesnes
75, rue de Malacombe
38070 St. Quentin-Fallavier
France
Phone +33 / 474 95 41 01
lfr.info@shi-g.com

Lafert Motores Electricos, S.L.U.

Poligono Pignatelli, Nave 27
50410 Cuarte de Huerva (Zaragoza)
Spain
Phone +34 / 976 503 822
les.info@shi-g.com

Lafert N.A. (North America)

5620 Kennedy Road - Mississauga
Ontario L4Z 2A9
Canada
Phone +1 / 800/661 6413 - 905/629 1939
lna.info@shi-g.com

Lafert Electric Motors (Australia)

Factory 3, 117-123 Abbott Road,
Hallam - VIC 3803
Australia
Phone +61 / (0)3 95 46 75 15
info@lafertaustralia.com.au

Lafert Singapore Pte Ltd

48 Hillview Terrace #06-06
Hillview Building - Singapore 669269
Phone +65 / 67630400 - 67620400
info@lafert.com.sg

Lafert (Suzhou) Co., Ltd.

No.3 Industrial Plant Building Yue Xi Phase 3,
Tian E Dang Lu 2011, 215104 Wuzong
Economic Development Zone, Suzhou
China
Phone +86 / 512 6687 0618
lsu.info@shi-g.com