

3-Phase Motors

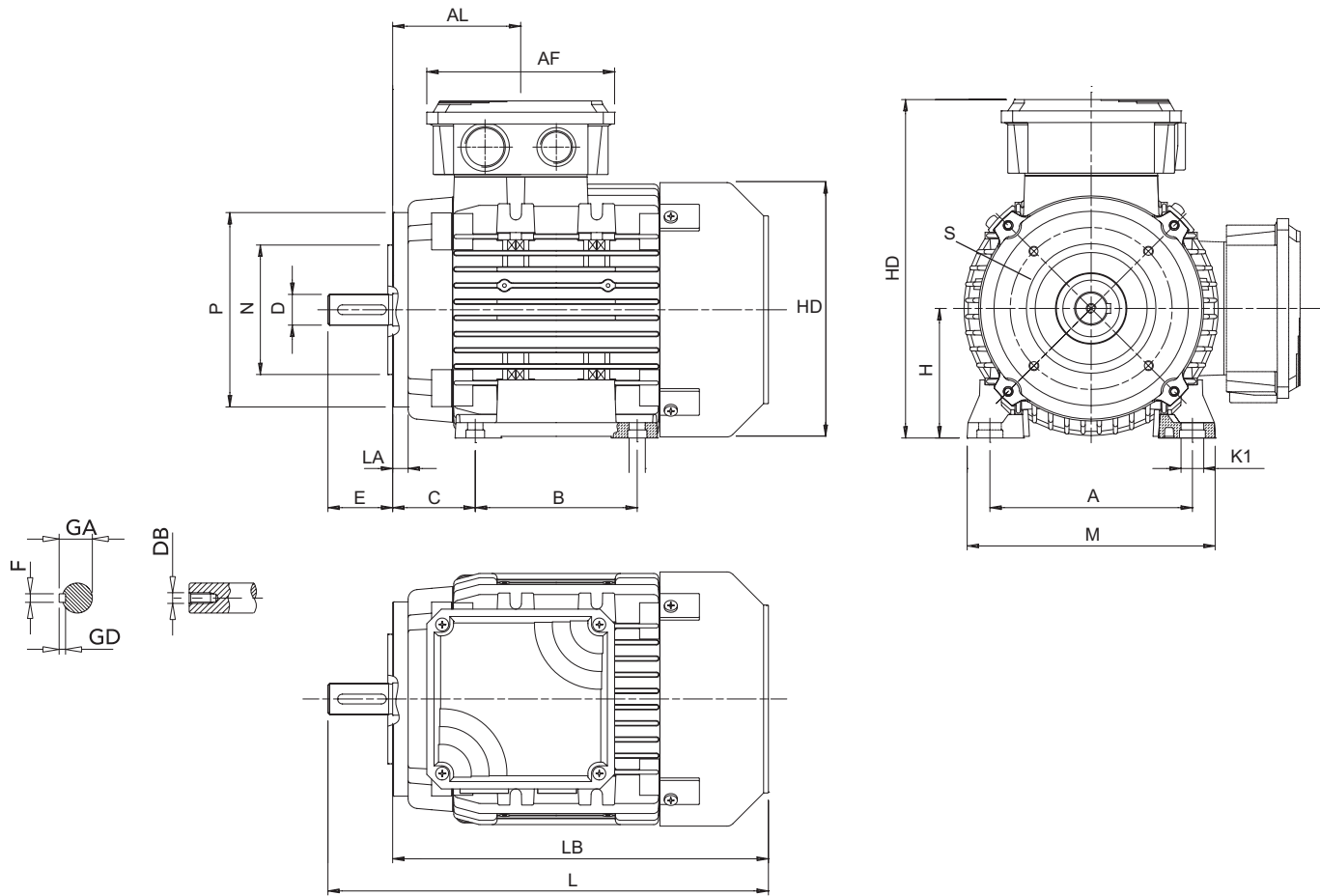

• F2 LEAD BOX IS STANDARD

MS Compact brake motor non-drive end shaft is not standard size - Please inquire

IM B14 - C Flange

All dimensions in mm

Frame																					AMPH		AMFV	AMBZ	MS			
	M	N	P	T	LA	S	H	A	B	C	K	HD	AC	HA	K1	AL	AF	D	E	F	GD	GA	DB	L	LB	L	L	L
56	65	50	80	2.5	8	M5	56	90	71	36	6	148	110	8	9	61	92	9	20	3	3	10.2	M3	188	168	-	-	-
63	75	60	90	2.5	8	M5	63	100	80	40	7	159	124	8	11	63	92	11	23	4	4	12.5	M4	211	188	-	267	226
71	85	70	105	2.5	8	M6	71	112	90	45	8	181	139	9	11	69	92	14	30	5	5	16	M5	246	216	308	300	255
80	100	80	120	3	9	M6	80	125	100	50	10	209	159.5	9.5	14	79	116	19	40	6	6	21.5	M6	272	232	361	350	294
90S	115	95	140	3	9	M8	90	140	100	56	10	228	179.5	11	15	85	116	24	50	8	7	27	M8	317	267	392	403	340
90L	115	95	140	3	9	M8	90	140	125	56	10	228	179.5	11	15	85	116	24	50	8	7	27	M8	317	267	417	403	340
100L	130	110	160	3.5	10	M8	100	160	140	63	11	245	198	12	17	91	116	28	60	8	7	31	M10	366	306	462	465	379
112M	130	110	160	3.5	10	M8	112	190	140	70	12	272	225	15	19	92	116	28	60	8	7	31	M10	388	328	479	487	396
132S	165	130	200	3.5	30	M10	132	216	140	89	12	326	261	17	20	100	133	38	80	10	8	41	M12	485	365	562	592	480
132S 2P 7.5 kW	165	130	200	3.5	30	M10	132	216	140	89	12	326	261	17	20	100	133	38	80	10	8	41	M12	465	385	562	592	480
132M 2P	165	130	200	3.5	30	M10	132	216	178	89	12	326	261	17	20	120	133	38	80	10	8	41	M12	505	425	560	612	500
132M 4P	165	130	200	3.5	30	M10	132	216	178	89	12	326	261	17	20	120	133	38	80	10	8	41	M12	505	405	560	612	500
160M	215	180	250	4	36	M12	160	254	210	108	14	398	316	23	18	146	150	42	110	12	8	45	M16	608	498	723	721	614
160L	215	180	250	4	36	M12	160	254	254	108	14	398	316	23	18	168	150	42	110	12	8	45	M16	652	542	715	763	658